



We Are Dispensers

Tape Dispensers

Wire Harnessing

VHB Application

APPLIANCE

Non-Adhesive Cutters

Product ID

SOLAR & WIND POWER

Battery Manufacturing

Parts Assembly

FOOD & BEVERAGE

RFID

Label Dispensers

Barcodes
Promotional Labels

pharmaceutical

ELECTRONICS

Safety Seal AUTOMOTIVE

MANUFACTURING

PACKAGING Die-Cut Gaskets

Heat Shrink Tubing

ZCM1000/M1000 Series



START International
4270 Airborn Drive, Addison, TX 75001, U.S.A.
Tel 1.972.248.1999 • Fax 1.972.248.1991 • service@STARTInternational.com
www.STARTInternational.com



CONTENTS

Read this user’s manual before use to ensure proper operation. Keep the manual on hand for reference in case there is a problem.

Warranty Information	Page 2
Notes	Page 3
Features	Page 3
Description of Parts and Functions	Page 4
Operation	Page 5-6
Specifications	Page 7
Troubleshooting	Page 7
Preventive Maintenance	Page 8
Exploded Views/Parts Breakdown	Page 9-13
Parts List	Page 14-22

WARRANTY POLICY FOR LD SERIES LABEL DISPENSERS

START International warrants all parts on ZCM series tape dispensers against defects in design, materials and workmanship for a period of 360 days. Parts excluded from this are: cutting blades, silicone rollers and cutter liners; these parts are considered “wear parts”. Labor to replace defective parts will be performed at no charge for the first 180 days after date of purchase. Warranty does not cover transportation costs.

START International’s sole obligation under this warranty is limited to repair, replacement or credit of the purchase price, at our option, which do not properly perform the function for which they were designed.

Warranty repair is contingent upon START’s examination and determination that alleged defects have not been caused by misuse, abuse, improper installation or application, repair, alteration, accident or neglect in use, storage, transportation or handling.

The above warranty and remedy constitutes START International’s sole liability hereunder and are in lieu and exclusive of all other warranties and remedies expressed, implied, or statutory, including, but not limited to, those of merchantability and fitness for a particular purpose.

REPAIR POLICY

Contact START INTERNATIONAL to determine nature of problem.

Furnish START with the following information:

1. Who the unit was purchased from.
2. Model number and serial number.
3. Date purchased (copy of invoice or packing slip required).

START will issue an RMA (Return Material Authorization) for the repair. Return machine to START by freight, insured and prepaid. START will notify the customer if there is a repair charge. A \$25.00 evaluation charge will apply to all non-warranty repairs, which will be applied to repair change.

For the full Warranty & Repair policy please visit www.STARTInternational.com

FEATURES

- Will dispense butt-cut and die-cut material.
- Adjustable photosensor for pinpoint accuracy.
- Handled lock rod makes scrap removal easy.
- No tools required for adjustment.

NOTES

- Keep strip plate free of adhesive build-up.
- Clean photosensor with compressed air or dry cloth.
- Do not drop the dispenser or subject it to heavy shock.
- Turn off machine when not in use.

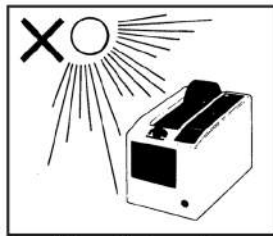

Do not leave the tape dispenser in direct sunlight.

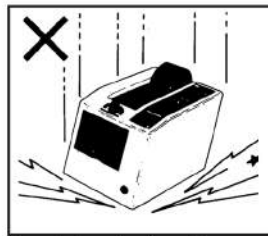

Do not drop the tape dispenser or subject it to heavy shocks.

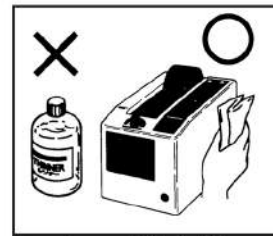

Do not use volatile liquids (thinner, benzene, etc.) to clean the dispenser. Wipe with dry cloth only.

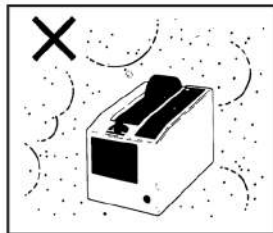

Do not use the tape dispenser in humid or dusty places.

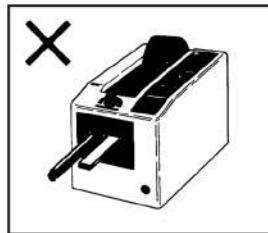

Do not insert bars or plates into the tape outlet – this will damage the blade.

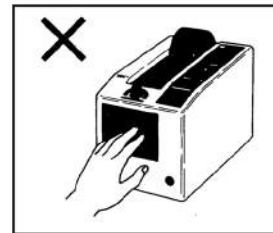

Do not insert your fingers into the cutting head!

DESCRIPTION OF PARTS AND FUNCTIONS



POWER Switch



FEED Roller



SEPARATING Roller



- **POWER Switch**
Press to turn power ON or OFF.



- **REVERSE Key**
Feed Roller reverses. Use this key to change tape.



- **TAPE LENGTH Display**
The last digit indicates millimeters and the first two digits centimeters.



- **ADVANCE Key**
Tape dispenses as long as key is pressed.



- **LENGTH ADJUSTMENT Keys**
Press mm key to set tape length in mm. Press cm key to set tape length in cm.



- **RESET Key**
Length display is reset to 20mm. This key can be used as an emergency stop.



- **CUT Key**
Press to cut tape.



- **ADVANCE / CUT Key**
Feeds tape to the preset length and cuts automatically.



- **PRESSURE Knob**
Adjusts top roller to change pressure on tape.

OPERATION

Using Automatic Feed:

1. Plug in power cord and turn unit on.
2. Set tape on the center of reel and stick the end of the tape onto the metal feed roller.
Press ADVANCE key until tape feeds through cutting unit. If the tape will not feed through the cutter, fold corners of the tape to form a triangle shape and re-feed (Fig. A).
3. Press CUT key to cut tape.
4. Set the tape length.
Press MM key to set length of 0-9mm.
Press CM key to set length of 20-990 mm.
5. Set PRESSURE knob
 - If tape curls or slips, increase pressure.
 - If tape creases, decrease pressure.
6. Turn sensor switch ON. Tape will be fed to set length and cut. When the piece of tape is removed from machine, another piece will be fed and cut. (Turn sensor switch OFF when not in use.)



Using ADVANCE / CUT key

With AUTO SENSOR switch OFF, press ADVANCE / CUT key. Tape will be fed to set length and cut.

Using ADVANCE key

Press ADVANCE key until desired tape length has been fed. (This key overrides the preset length.) Press cut to cut tape.

Changing tape

Press the REVERSE key. The feed roller will rewind the tape away from cutter area. Remove the tape manually.

In case of tape jam

Press REVERSE key to remove tape from cutter area. Rewind and replace tape on roller. Also, remove cutter unit to verify no tape is stuck on roller or cutter.

OPERATION (CONT'D)

To Replace Cutter Unit

Turn off auto sensor and power before removing cutter unit. Pull sensor plug out, then pull cutter unit forward while pressing the knob on the top of the unit (Fig. 1).

To replace blades, remove the two screws inside head. Blade can then be lifted out and replaced. Before remounting the cutter unit to the frame, the lower blade must be bottomed out. If it is not completely down, use a screwdriver to lower it (Fig. 2).

Remount the cutter unit by aligning the bottom of the unit then pushing in the top.

Replacing the Separating Roller

Turn off the sensor and power before removing the separating roller. Remove the cutter unit, then remove the two screws (Fig. 3).

To remove roller holder, grip rubber ring in the center of separating roller and pull. Then remove the screws on the left and right of the roller holder and pull off shaft and gear (Fig. 4).

- Set the tape properly as described in these instructions. (If the end of the tape is folded when the tape is set, the tape may jam at the tape outlet.)
- This machine will cut virtually any type of pressure sensitive tape (aluminum, filament, etc.). If tape is thicker than .05" or thinner than .03", test for compatibility.
- Because of tape differences (elasticity, stickiness, etc.), some tapes may not cut at the set length. If this occurs, adjust the set length accordingly.
- If tape sticks to the blade, remove the cutter unit, clean with alcohol and apply silicone oil to the blade.
- To reduce jamming, remove tape from machine when not in use.

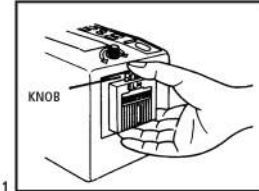

FIG. 1

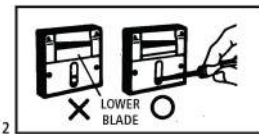

FIG. 2

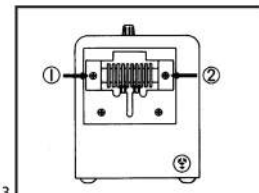

FIG. 3

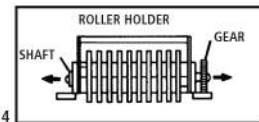

FIG. 4



SPECIFICATIONS

Model	zcM1000	zcM2000
Display	3-Digit LED	
Applicable Tape Width	.28" - 2" (7 - 50mm)	
Core Diameter	3" (optional 1", 1.25", 1.5")	
Tape Length Set Limit	.79" - 39" (20-999mm) ± .040"	
Memory Settings	1	3
Drive	DC Motor for Tape Advancement and Tape Cut	
Power Consumption	18W	
Power (AC)	117V 50/60Hz or 230V 50/60Hz	
Ambient Temperature	41° - 104°F (5° - 40°C)	
Ambient Humidity	Less than 80% RH	
Dimensions	5.4 x 8.6 x 6" (14 x 22 x 15cm)	
Weight	5.3 lbs (2.4 kg)	

TROUBLE SHOOTING

When problems occur, carry out the following procedures. If the tape dispenser does not operate normally after following the troubleshooting procedures, contact your supplier.

1. If the motor does not drive:
 - Check that the power cord is plugged in.
 - Check that the power switch is turned on.
2. If the tape does not cut:
 - Make sure the cutter unit is set properly and clean.
3. If the LED does not light:
 - Check that the power cord is plugged in.
 - Check that the power switch is turned on.
4. If the tape does not advance:
 - Check if the tape is jammed at the roller or in the cutter unit.
 - Check that the tape is set properly.
5. If the auto sensor does not work:
 - Check that the sensor plug is plugged in.
 - Check that the sensor switch of cutter unit is on.
 - Check that the sensor part of the cutter unit is not stained.
6. If the tape advancing does not stop:
 - Check that the tape is centered. If not, set the tape at the center of the feed roller so that the sensor will see the tape.



PREVENTIVE MAINTENANCE

- WEEKLY - Remove cutting head. Clean and look for missing roller rings. Replace as needed.
- MONTHLY- Remove blade spring and blades to inspect cutter liners. Place one drop of silicone oil on each liner, or replace if worn. Inspect feed roller and blades for tape fragments or adhesive buildup. Clean with alcohol.

ADDITIONAL INFORMATION FOR THE ZCM2000

MEMORY Key

The reverse key on the ZCM1000 is changed to the MEMORY (M) key on the ZCM2000. (The reverse function can be accessed by pressing the FEED key and the M key at the same time. This function is for changing tape.)

Setting Memories

1. Press and hold the M key until the LED display flashes.
2. Using the cm and mm keys, set the desired length for first cut.
 - A. The mm key controls the millimeter setting (1 digit).
 - B. The cm key controls the centimeter setting (2 digits).
(Ex: 125mm = 12cm and 5mm.)
 - C. Press M key to record memory. (The display will then flash "999".)
3. Set additional lengths as shown in #2. (If only two lengths are needed, record "999" as last length — "999" length will not be memorized.)
4. After lengths are set, the display will flash "0".

Press mm key to switch between "0" and "5":

 - On "0", the machine will feed and cut the first set length until the M key is pressed, then it will feed the second length until the M key is pressed, and so on.
 - On "5", the machine will feed and cut the recorded lengths in series.
5. When set correctly, press and hold the M key until the display stops flashing. The first preset length will be shown on the display and the unit is ready to use.
6. Programmed tape lengths will be fed and cut in order when using either the sensor unit automatic feed and cut or the ADVANCE / CUT button.
7. If RESET (20) key is pressed, all of the memory will be erased.

EXPLODED VIEWS / PARTS BREAKDOWN

REMOVE BODY COVER AND BOTTOM PLATE

TO REMOVE BODY COVER:

1. REMOVE AUTO FEED CUTTER UNIT (550-1)
2. REMOVE FOUR SCREWS (233)
3. REMOVE PRESSURE KNOB (106)
4. LIFT COVER FROM UNIT

TO REMOVE BOTTOM PLATE:

1. REMOVE GROUND SCREW FROM BASE (234)
2. REMOVE FOUR SCREWS FROM BOTTOM OF UNIT (228)
3. REMOVE TWO SCREWS FROM BOTTOM OF UNIT (113)
4. REMOVE TWO SCREWS FROM FRONT OF BASE (228)

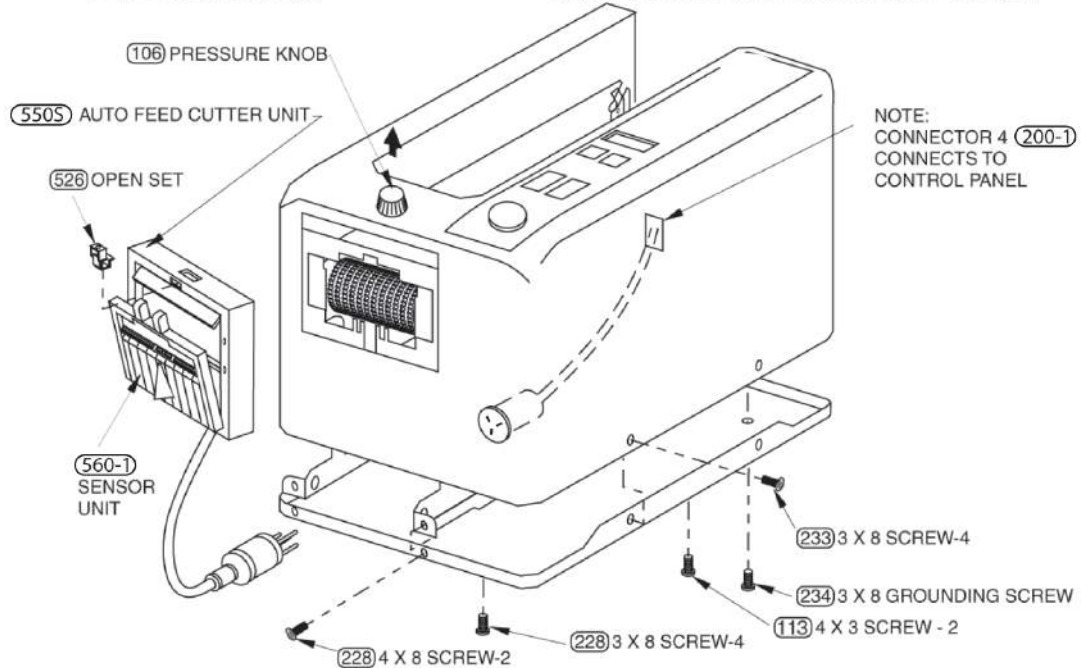

CHANGE THE SEPARATING ROLLER

1. REMOVE TWO SCREWS (233)
2. GRIP RUBBER RINGS (138)
3. LIFT ROLLER UNIT FROM TAPE UNIT

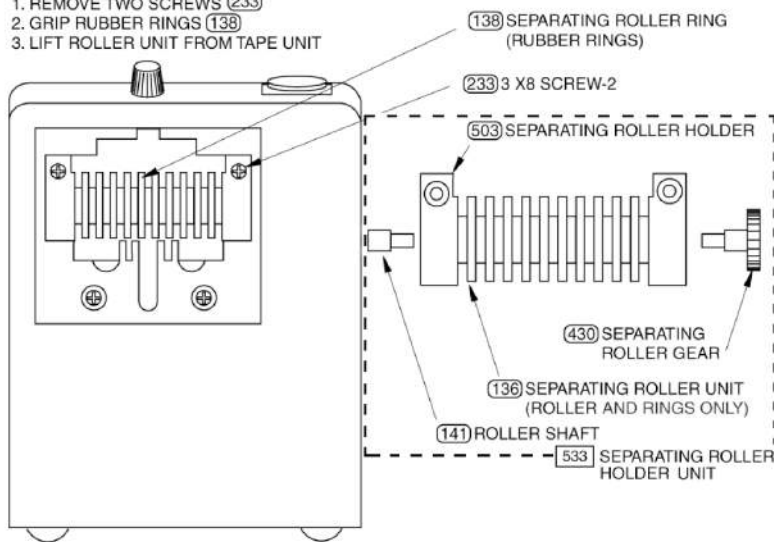

Numbers in balloons (100) represent the last digits in replacement part number.
When ordering, ask for ZCM1000P _ _ _

EXPLODED VIEW

FRONT HOLDER STRUCTURE

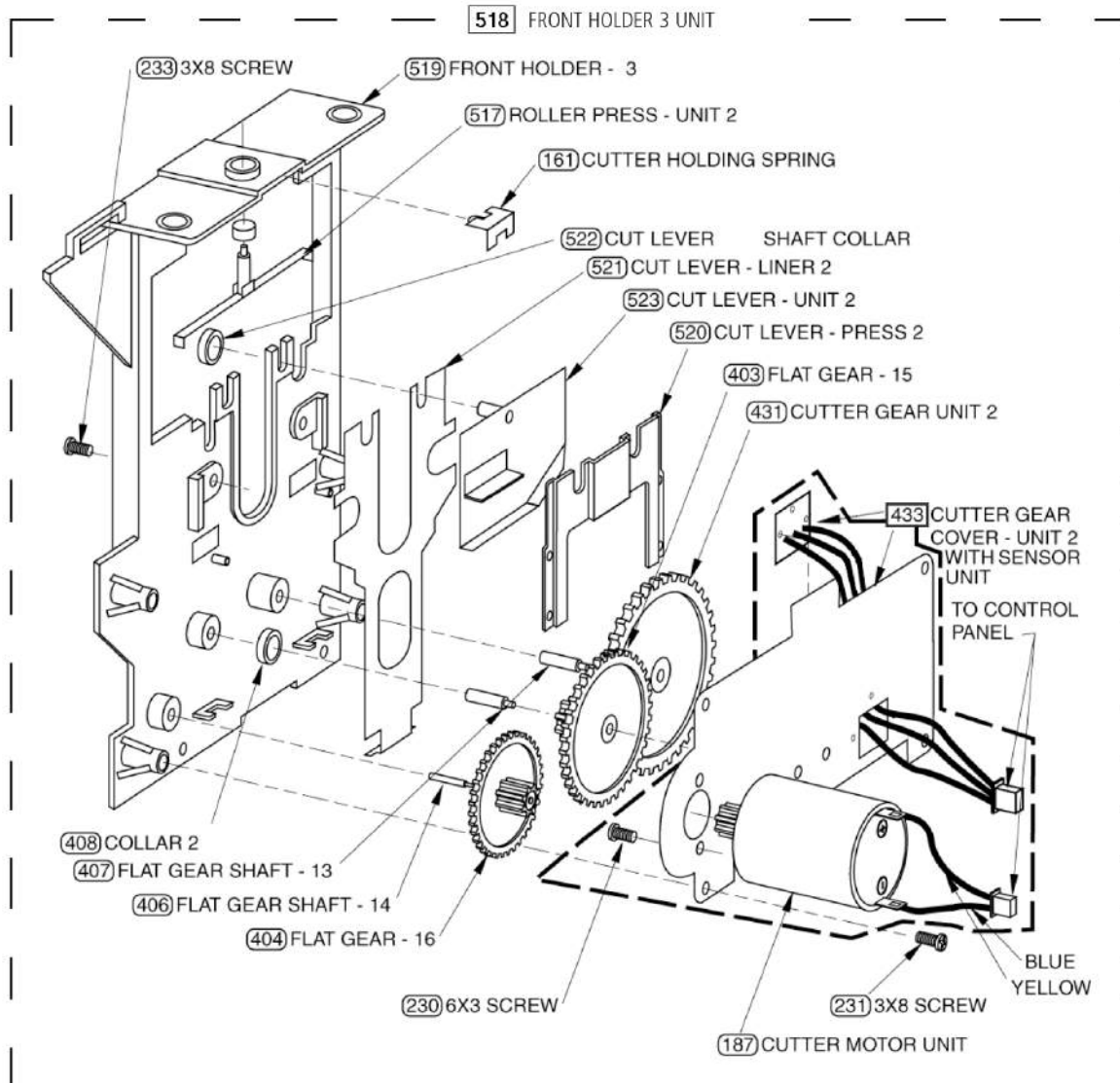

Numbers in balloons (100) represent the last digits in replacement part number.
When ordering, ask for ZCM1000P _ _ _

EXPLODED VIEW

FEED STRUCTURE

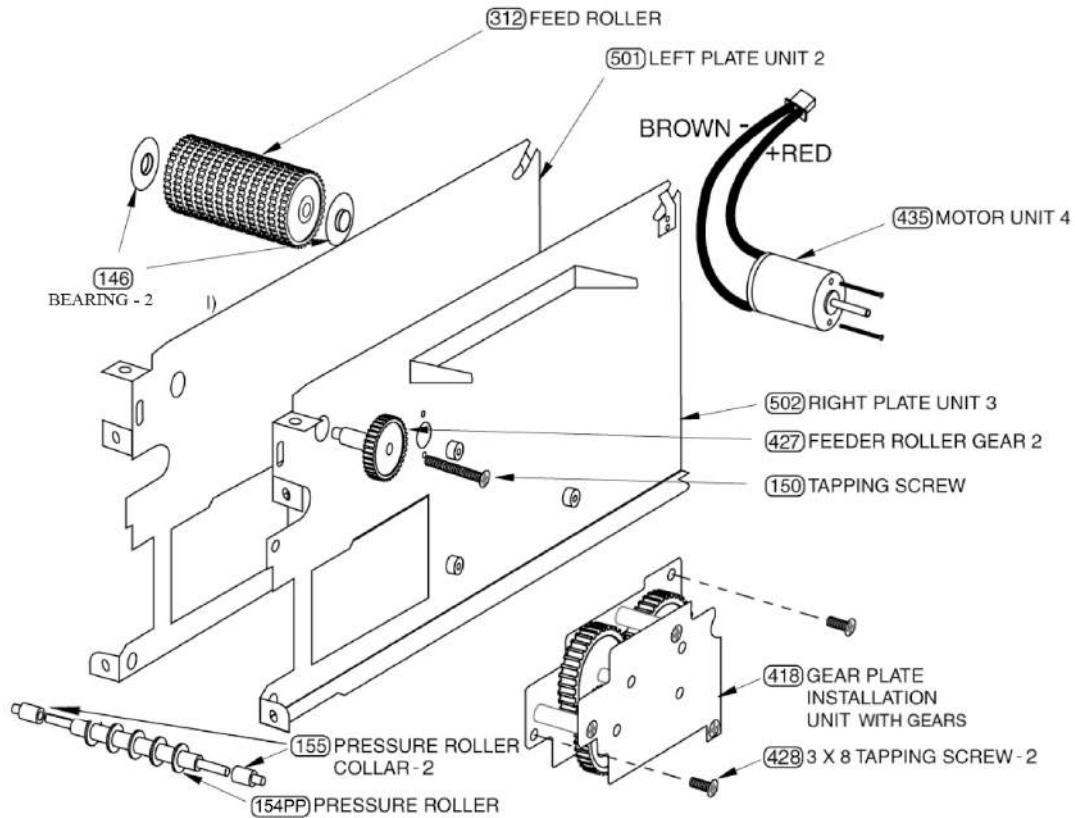

REMOVING SENSOR UNIT

1. OPEN SENSOR UNIT FROM BLADE HOLDER UNIT
2. PRESS SENSOR UNIT FORWARD (UP) TO REMOVE FROM CUTTER HOLDER UNIT

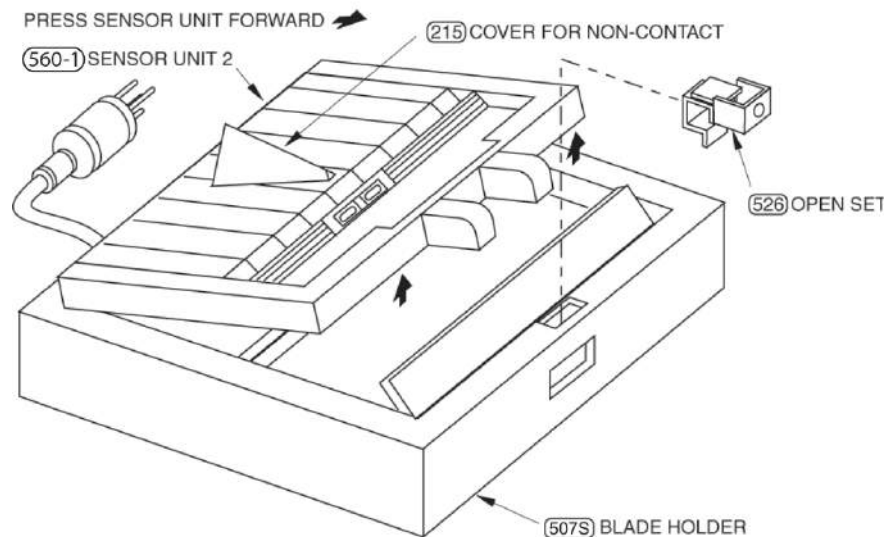

Numbers in balloons (100) represent the last digits in replacement part number.

When ordering, ask for ZCM1000P ---

EXPLODED VIEW

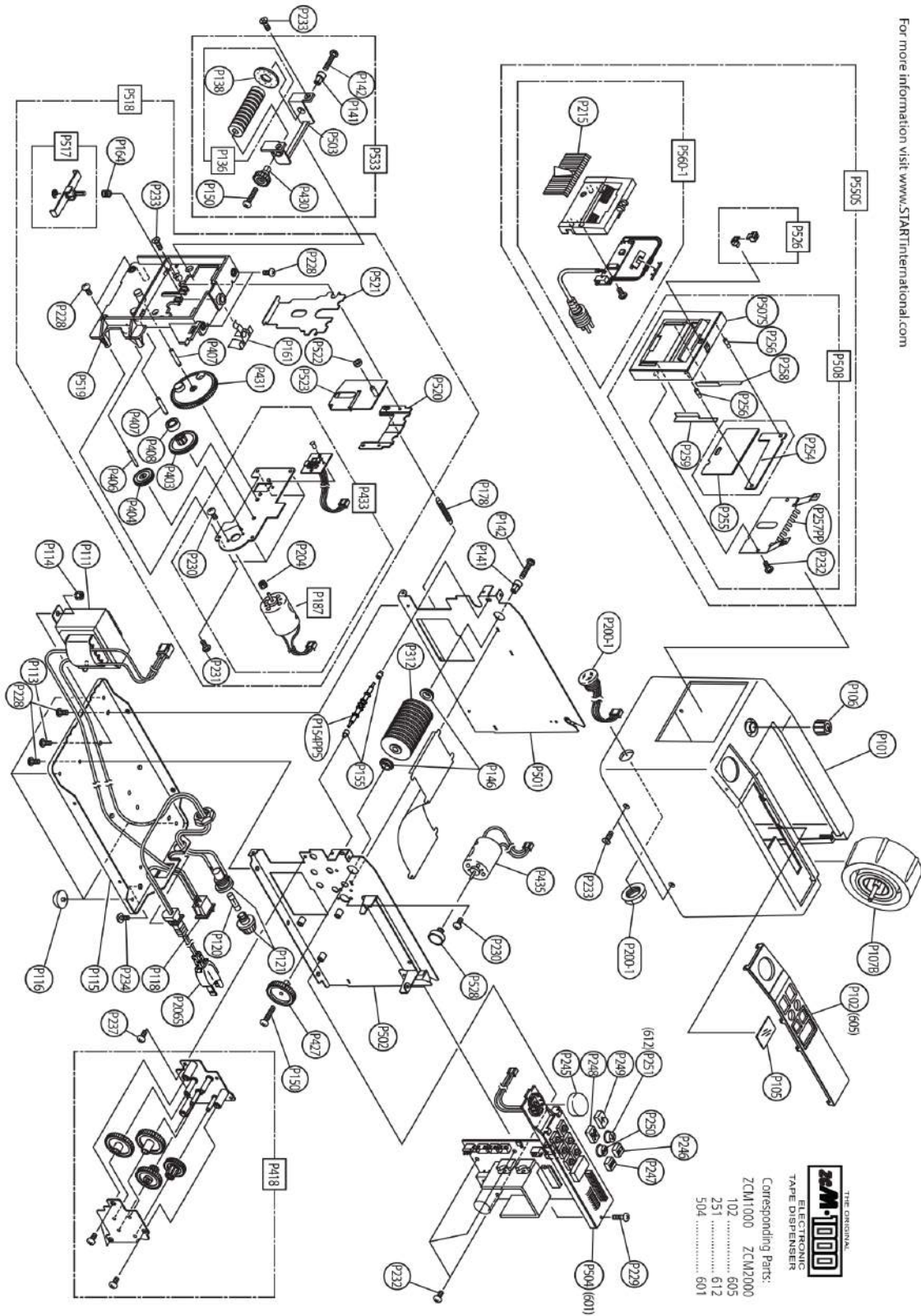

For more information visit www.STARTInternational.com



ZEM-1000
 THE ORIGINAL
 ELECTRONIC
 TAPE DISPENSER
 Corresponding Parts:
 ZCM1000 ZCM2000
 102 605
 251 612
 504 601

EXPLODED VIEW

BOTTOM PLATE WIRING

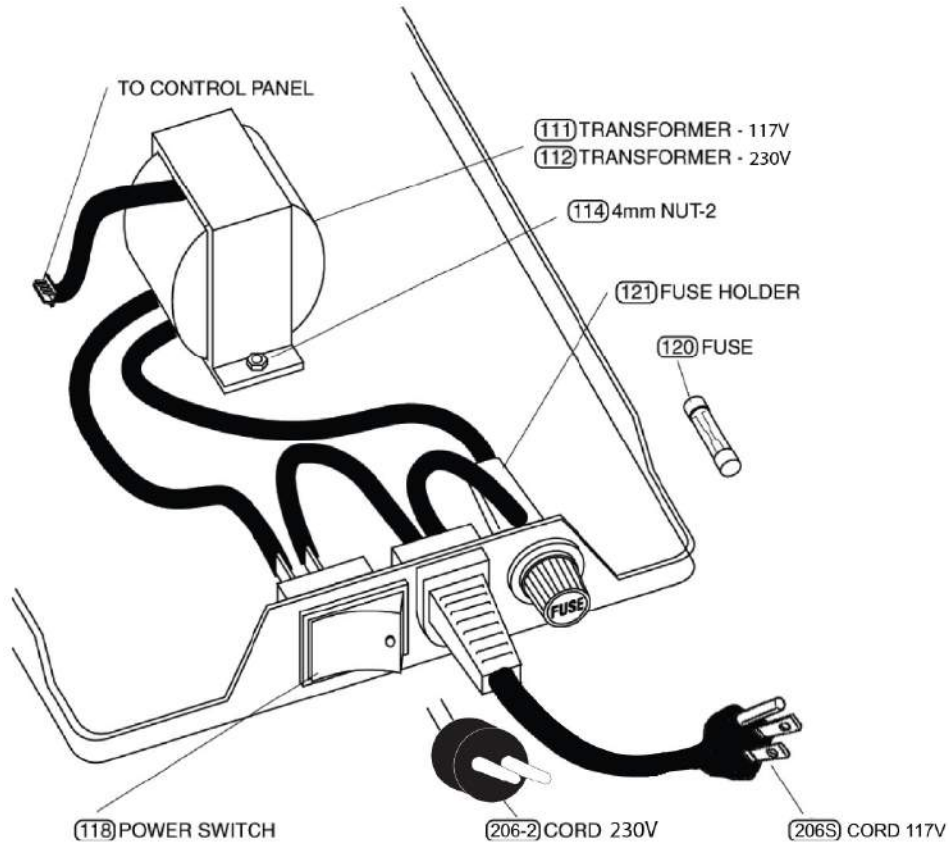



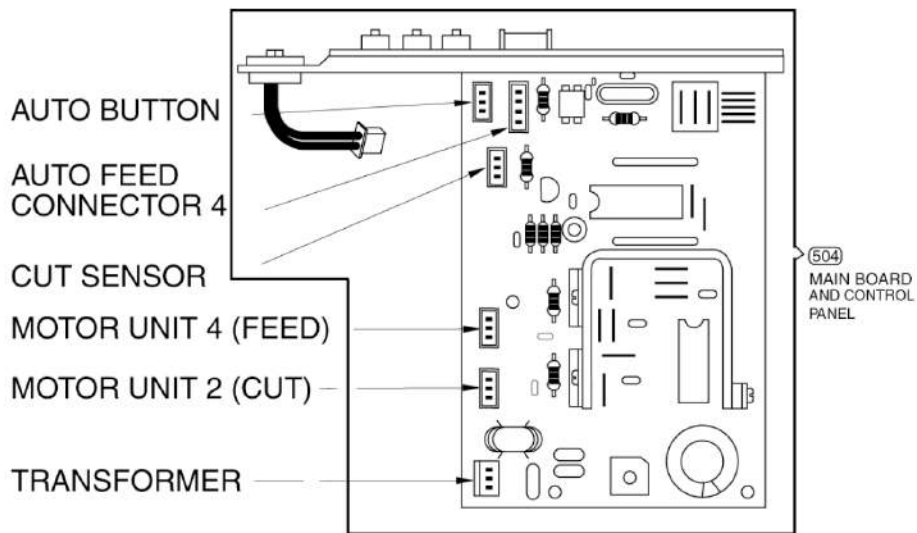



CONTROL PANEL CONNECTIONS

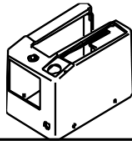
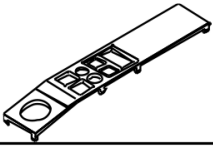

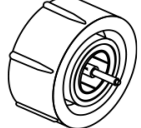
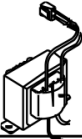
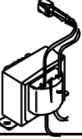







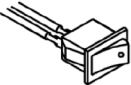

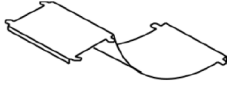

Numbers in balloons (100) represent the last digits in replacement part number.
When ordering, ask for ZCM1000P _ _ _









PARTS

Part #	Part Name	Illustration	Notes
zcM1000P101	Body cover		Standard Part
zcM1000P102	Panel cover		Standard Part
zcM1000P105	LED cover		Standard Part
zcM1000P106	Pressure Knob		Standard Part
zcM1000P107B	Core holder		Standard Part
zcM1000P111	Transformer 117V		Standard Part (on 117 Volt Machines)
zcM1000P112	Transformer 230V(CE)		Standard Part (on 230 Volt Machines)
zcM1000P113	Screw (4* 8)		Standard Part (To hold transformer on base)
zcM1000P114	Nut with washer		Standard Part (4mm)
zcM1000P115	Base		Standard Part
zcM1000P116	Rubber feet		Standard Part





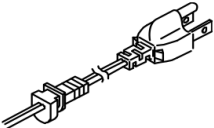
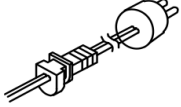
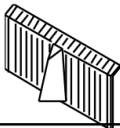







PARTS

Part #	Part Name	Illustration	Notes
zcM1000P118	Power switch		Standard Part
zcM1000P120	Fuse (1A)		Standard Part
zcM1000P121	Fuse holder		Standard Part
zcM1000P124	Center frame		Standard Part
zcM1000P136	Separating roller unit		Standard Part (Used with P138)
zcM1000P138	Separating roller ring Serrated		Standard Part (Pack of 20)
zcM1000P138-1	Separating roller ring		Standard Part (Pack of 20)
zcM1000P141	Roller shaft		Standard Part
zcM1000P142	Screw (3*20)		Standard Part (To Mount to P136)
zcM1000P146	Bearing		Standard Part
zcM1000P150	Screw (3*25)		Standard Part (To Mount feed roller)
zcM1000P154PP5	Pressure roller 5T		Standard Part (5 teeth for less pressure)
zcM1000P155	Pressure roller collar		Standard Part









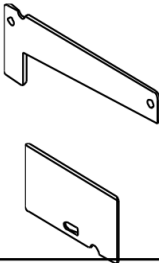

PARTS

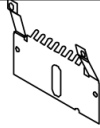
Part #	Part Name	Illustration	Notes
zcM1000P161	Cutter holder spring		Standard Part
zcM1000P164	Pressure roller spring		Standard Part
zcM1000P178	Earth spring		Standard Part
zcM1000P182	Flat rivet		Standard Part
zcM1000P187	Cutter motor (Yellow & Blue line)		Standard Part
zcM1000P200-1	Connector 4 (3 pins)		Standard Part
zcM1000P204	Pinion gear		Standard Part
zcM1000P206S	Power cord (For 117V)		Standard Part (USA, Plug type B)
zcM1000P206-2	Power cord (For 230V)		Standard Part (German/EU, Plug type F)
zcM1000P215	Sensor unit cover		Standard Part
zcM1000P228	Screw (3*8)		Standard Part (To mount front holder)
zcM1000P229	Screw (3*14)		Standard Part (To mount control panel)









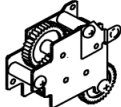

PARTS

Part #	Part Name	Illustration	Notes
zcM1000P230	Screw (2.6*3)		Standard Part (To mount motor, Gold color)
zcM1000P231	Screw (3*10A)		Standard Part (To mount cutter gear cover)
zcM1000P232	Screw (3*5)		Standard Part (To mount cutter spring)
zcM1000P233	Screw (3*8)		Standard Part (To mount body)
zcM1000P234	Screw (3*8)		Standard Part (To ground earth)
zcM1000P237	Screw (4*6)		Standard Part (To mount gear unit)
zcM1000P245	Advance / Cut button		Standard Part
zcM1000P246	"cm" Button		Standard Part
zcM1000P247	"mm" Button		Standard Part
zcM1000P248	"Cut" Button		Standard Part
zcM1000P249	"Advance" Button		Standard Part
zcM1000P250	"20" Button reset		Standard Part





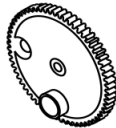
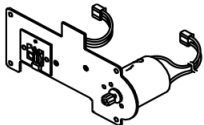

PARTS

Part #	Part Name	Illustration	Notes
zcM1000P251	"Reverse" Button		Standard Part
zcM1000P254/5	Blade set (Upper & Lower)		Standard Part (Special coated blades) Standard Part (Special coated blades)
zcM1000P256	Top Blade Holder		Standard Part
zcM1000P257PP	Blade spring with comb		Standard Part
zcM1000P258	Blade liner (Right)		Standard Part
zcM1000P259	Blade liner (Left)		Standard Part
zcM1000P289	Silicone oil		Included with all models
zcM1000P312	Feed roller 2		Standard Part
zcM1000P403	Flat gear 15		Standard Part
zcM1000P404	Flat gear 16		Standard Part
zcM1000P406	Flat gear shaft 14		Standard Part

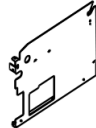
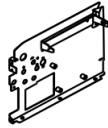
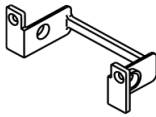

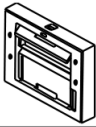
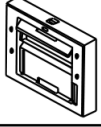
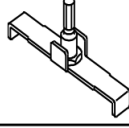
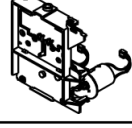

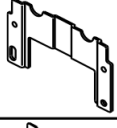





PARTS

Part #	Part Name	Illustration	Notes
zcM1000P407	Flat gear shaft 13		Standard Part
zcM1000P408	Collar 2		Standard Part
zcM1000P418	Gear unit		Standard Part
zcM1000P421	Flat Gear 11		Standard Part
zcM1000P422	Flat Gear 12		Standard Part
zcM1000P423	Flat Gear 13		Standard Part
zcM1000P424	Flat Gear 14		Standard Part
zcM1000P427	Feed roller gear 3		Standard Part
zcM1000P428	Screw (4*8)		Standard Part (to mount gear cover)
zcM1000P430	Separating roller gear		Standard Part
zcM1000P431	Cutter gear 2 unit		Standard Part
zcM1000P433	Cutter part gear cover 2 unit		Standard Part

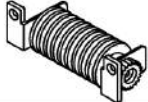
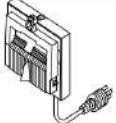

PARTS

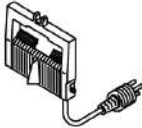
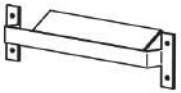
Part #	Part Name	Illustration	Notes
zcM1000P435	Feed motor (Red & Brown line)		Standard Part
zcM1000P501	Side frame (Left)		Standard Part
zcM1000P502	Side frame (Right)		Standard Part
zcM1000P503	Separating roller holder		Standard Part
zcM1000P504	PCB		Standard Part
zcM1000P507S	Cutter holder		Standard Part (Plastic Frame Only with Front Holes)
zcM1000P508S	Cutter holder unit 2		Standard Part (Plastic frame + blades with front holes)
zcM1000P517	Roller pressure unit 2		Standard Part
zcM1000P518	Front holder unit 3		Standard Part (frame + motor)
zcM1000P519	Front holder 3		Standard Part (Plastic frame only)
zcM1000P520	Cut lever press 2		Standard Part
zcM1000P521	Cut lever liner 2		Standard Part

PARTS



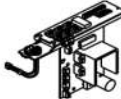







Part #	Part Name	Illustration	Notes
zcM1000P522	Cut lever collar		Standard Part
zcM1000P523	Cut lever unit 2		Standard Part
zcM1000P524	Open spring		Standard Part
zcM1000P525	Open knob		Standard Part
zcM1000P526	Open set		Standard Part
zcM1000P528	Pinion gear unit 2		Standard Part
zcM1000P533	Separating roller holder unit		Standard Part (with P138 roller rings)
zcM1000P550S	Auto feed cutter unit		Standard Part (with 3 flat pin connector) Complete Cutting Head
zcM1000P555	Sensor cover		(Plastic frame only)
zcM1000P560-1	Sensor unit		Standard Part (with 3 flat pin connector, frame + sensor)
zcM1000P680	Safety guard (With 4 screws)		Standard Accessory for 117V, Installed on 230V machines (Need P507-S)
zcM1000P901/901a	Stopper		Standard Part (to secure cutting head)

PARTS

Part #	Part Name	Illustration	Notes
ZCM2000P601	Main Board Unit 2		Standard Part (for zcM2000)
ZCM2000P605	Panel Cover		Standard Part (for zcM2000)
ZCM2000P612	Switch Button 3 (memory)		Standard Part (for zcM2000)

Modification KITS / PARTS

Please refer to STARTinternational.com for details on modifications.

zcM1000PB	B-kit		Complete Parts kit to convert to "B" modification
zcM1000PNM	NM-kit		Complete Parts kit to convert to "NM" modification
zcM1000P504-NS	NS-kit		Complete Parts kit to convert to "NS" modification
zcM1000P504-S	D-kit		Complete Parts kit to convert to "D" modification
zcM1000P533-1	T-kit		Complete Parts kit to convert to "T" modification
zcM1000P550M	C-kit		Part to convert to "C" modification
zcM1000P154	C-kit		Part to convert to "C" modification
zcM1000P550E	E-kit		Part to convert to "E" modification
zcM1000P107D	E-kit		Part to convert to "E" modification
zcM1000PCR	K-kit		Complete Parts kit to convert to "K" modification