

TDA080 (NM & K Models)



Quick Start Guide



4270 Airborn Dr. Addison, TX 75001, USA
972.248.1999 | tech@startinternational.com

▶ startinternational.com

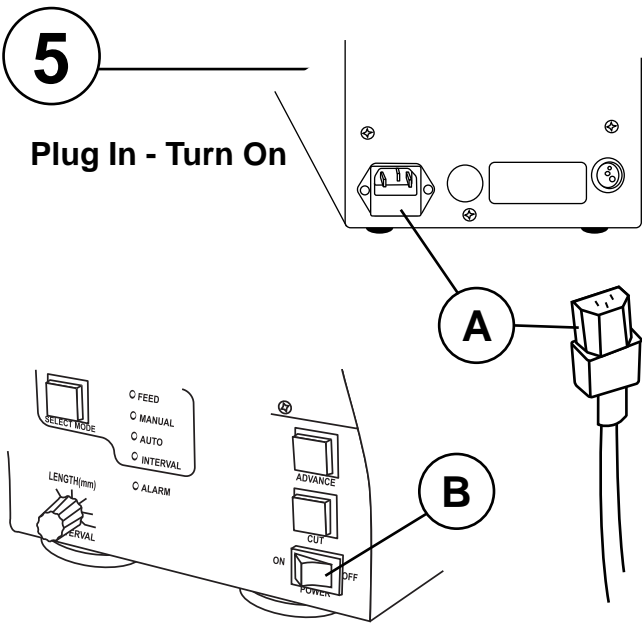

5 Plug In - Turn On

- A:** Connect power cord (in back)
- B:** Press power switch (on front) to turn on the machine

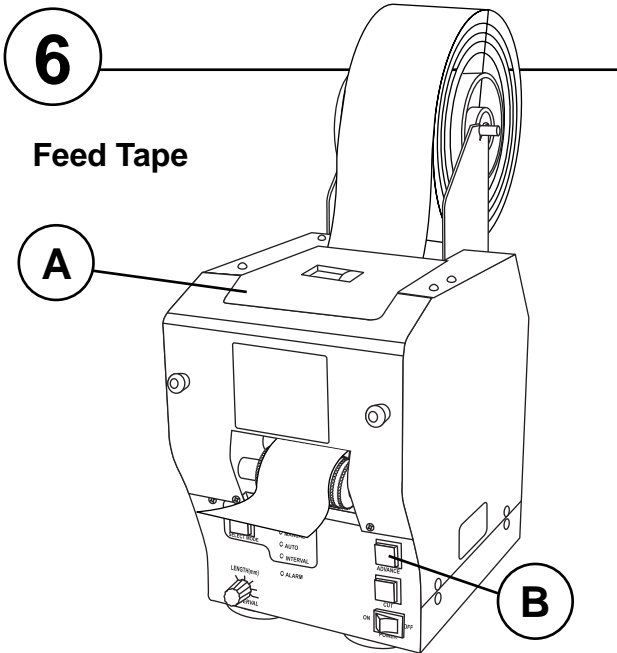

6 Feed Tape

- A:** Close top panel door
- B:** Press advance button to feed tape

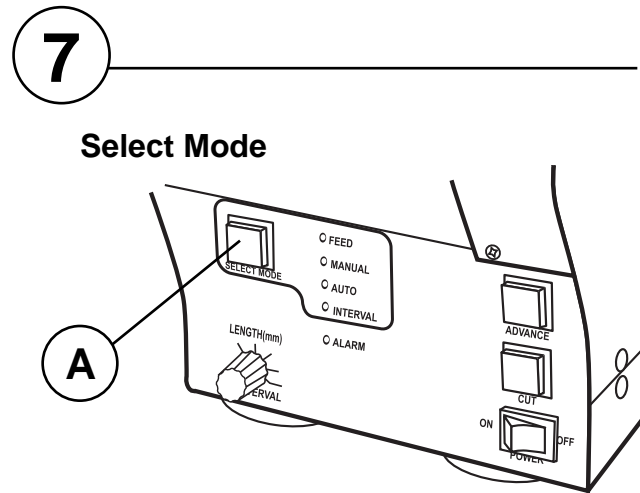

7 Select Mode

- A:** Choose desired operation mode:
- FEED
 - MANUAL (feed & cut)
 - AUTO (feed & cut)
 - INTERVAL (feed & cut)

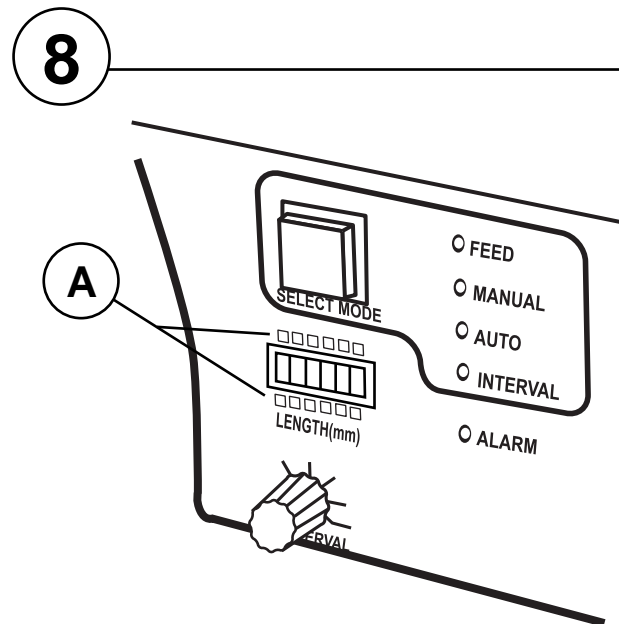

- A:** Set desired tape length (mm) by pushing up or down buttons

Need more help? Download the full manual or contact us

TDA080

Electric Tape Dispenser

ITEMS INCLUDED

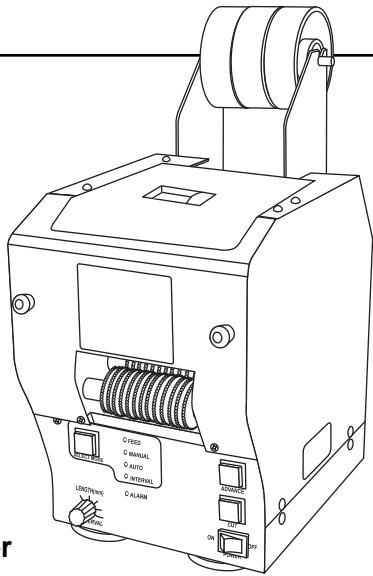

Dispenser

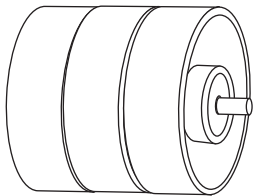

Core Holder

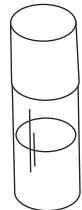

Silicon Oil

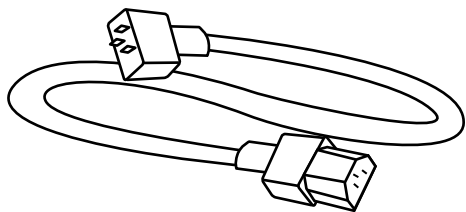

Power Cord

1

Power Off

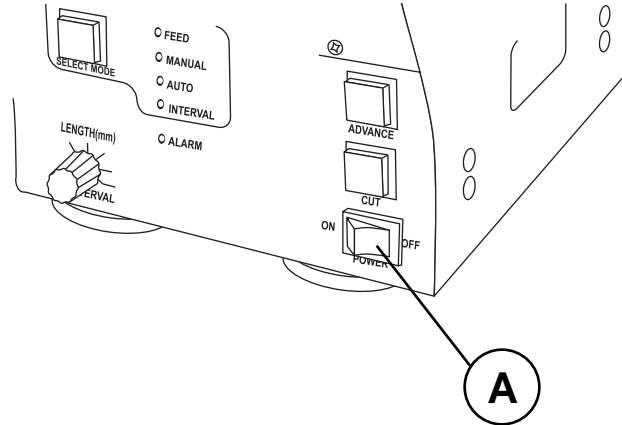

A: Ensure power button is set to off

2

Load Tape

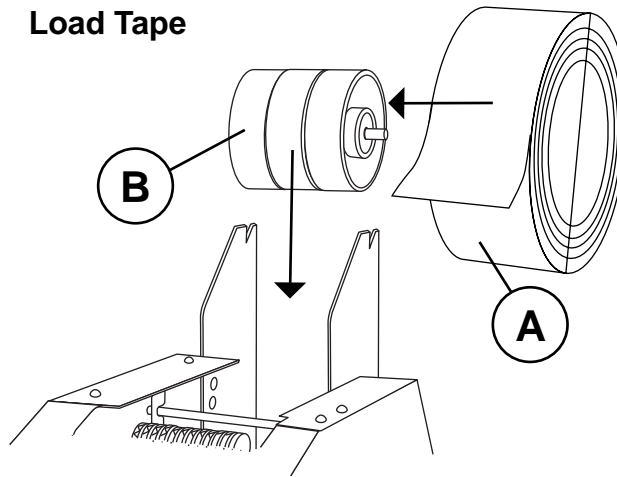

A: Slide tape roll onto core holder
B: Place loaded core on holding bracket

3

Open Top Panel

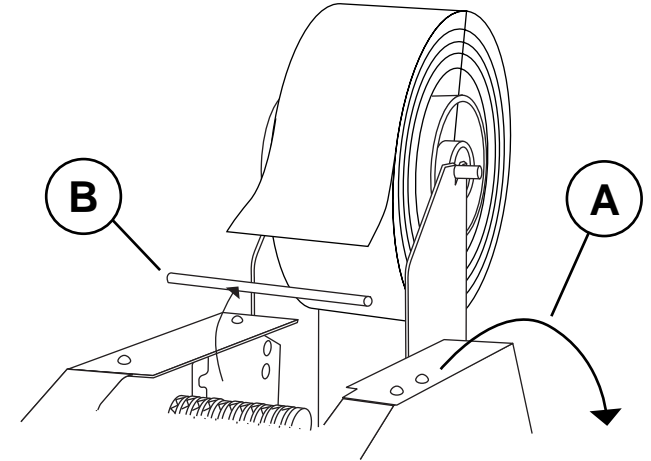

A: Open top door panel
B: Remove tape shaft from unit

4

Affix Tape to Feed Roller

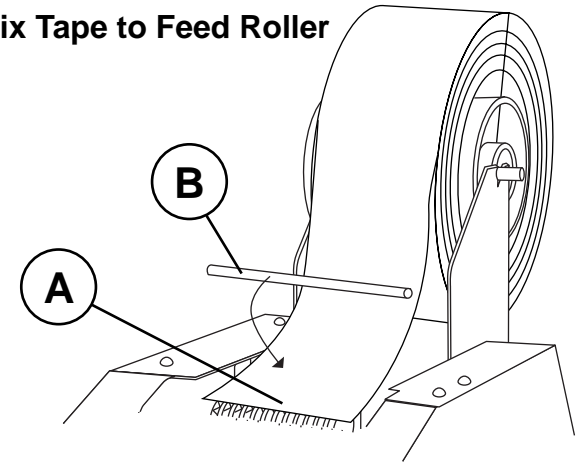

A: Affix tape onto feed roller
B: Re-insert tape shaft into guide