

5

Plug In - Turn On

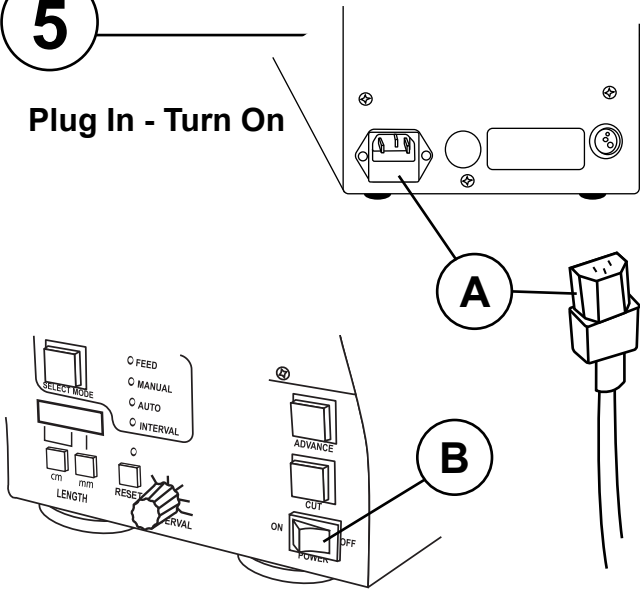

- A: Connect power cord (in back)
- B: Press power switch (on front) to turn on the machine

7

Select Mode

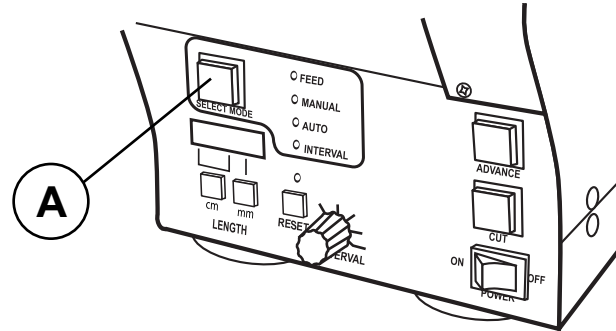

- A: Choose desired operation mode:
- FEED
 - MANUAL (feed & cut)
 - AUTO (feed & cut)
 - INTERVAL (feed & cut)

6

Feed Tape

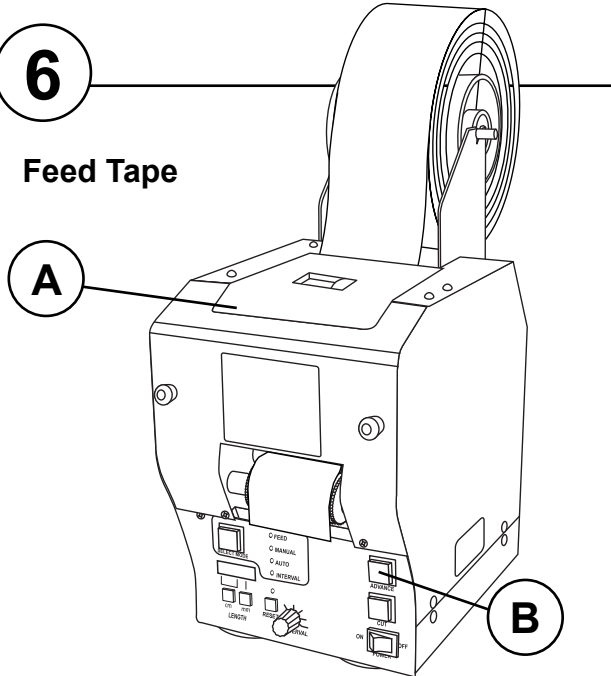

- A: Close top panel door
- B: Press advance button to feed tape

8

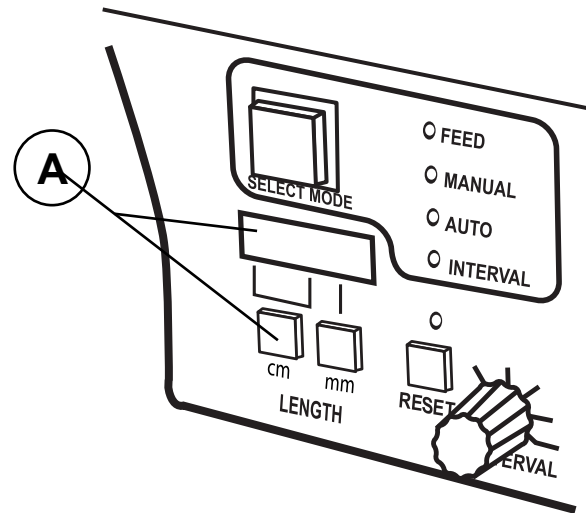

- A: Set desired tape length by pushing cm or mm buttons.

Need more help? Download the full manual or contact us

TDA080 (NM & NS Models)



Quick Start Guide



4270 Airborn Dr. Addison, TX 75001, U.S.A.
972.248.1999 | tech@startinternational.com

→ STARTinternational.com

TDA080

Electric Tape Dispenser

ITEMS INCLUDED

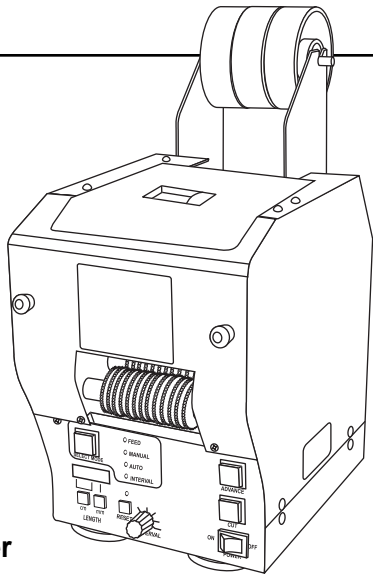

Dispenser

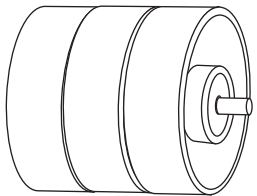

Core Holder

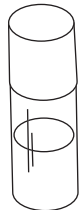

Silicon Oil

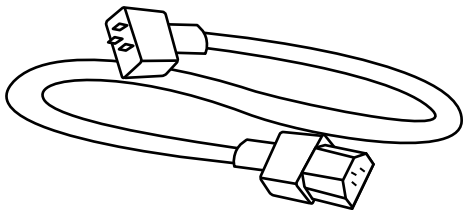

Power Cord

1

Power Off

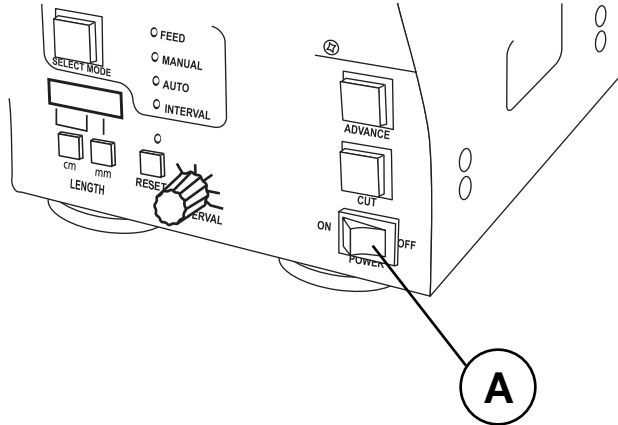

A: Ensure power button is set to off

2

Load Tape

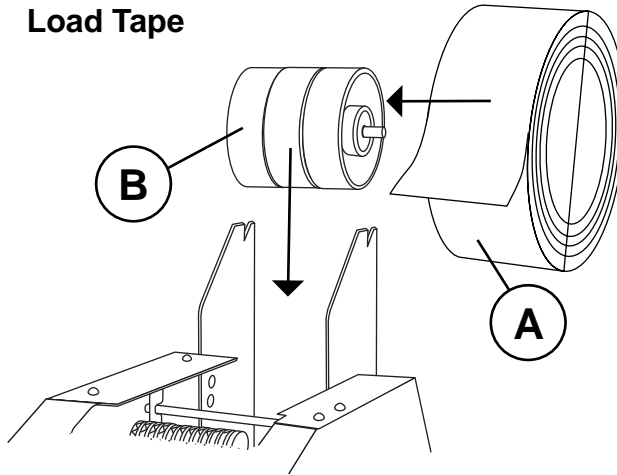

A: Slide tape roll onto core holder
B: Place loaded core on holding bracket

3

Open Top Panel

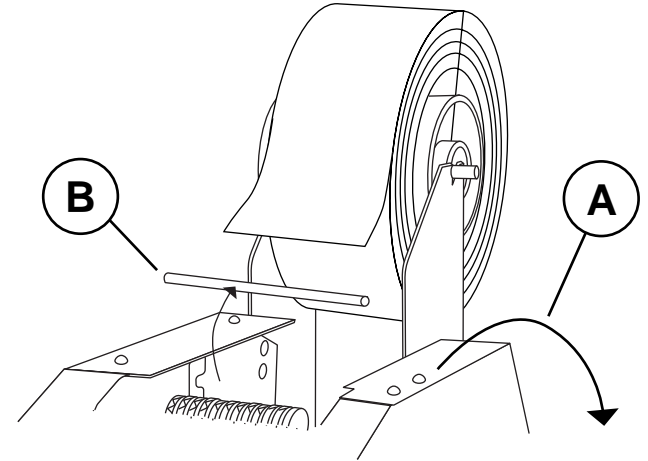

A: Open top door panel
B: Remove tape shaft from unit

4

Affix Tape to Feed Roller

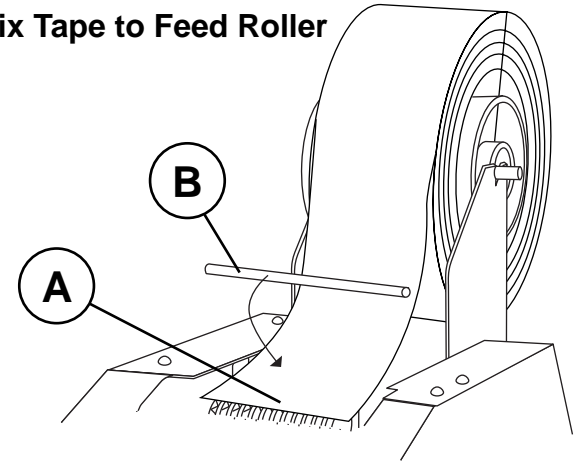

A: Affix tape onto feed roller
B: Re-insert tape shaft into guide