

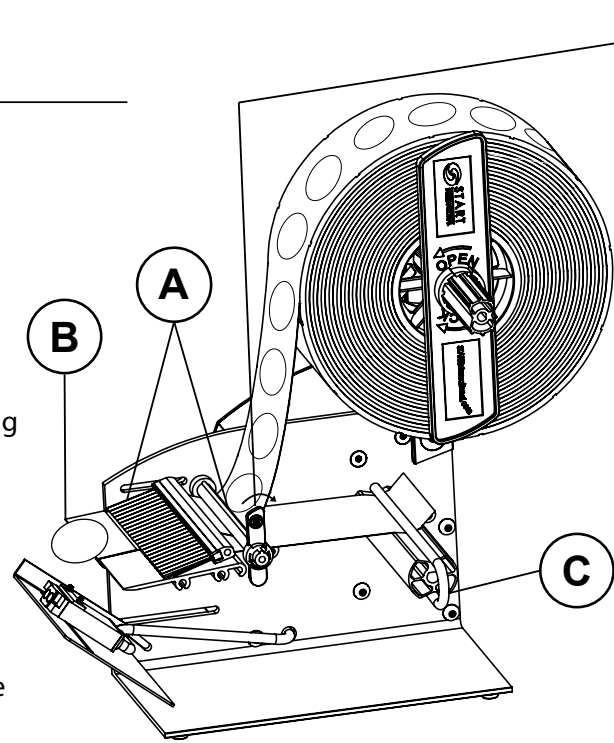

5

Load Dispenser

- A: Feed label liner **under** guide rod and brush
- B: Bend liner **around** strip plate and take-up hub (label will hang slightly over edge for lifting)
- C: Slide lock rod back into take-up hub to secure liner
- D: Slide small hub lock into guide rod and rotate clockwise **lightly** until it locks into place



D How To Use Small Hub Lock

Slide the hub lock into the rod

Turn the hub lock clockwise lightly until it locks into place

6

Adjust Sensor

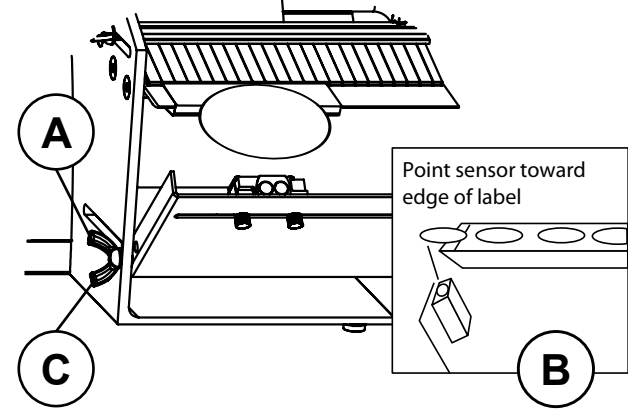

- A: Loosen wingscrew to adjust sensor plate
- B: Point sensor towards front edge of label
- C: Tighten wingscrew to secure sensor plate in place

7

Plug In & Turn On

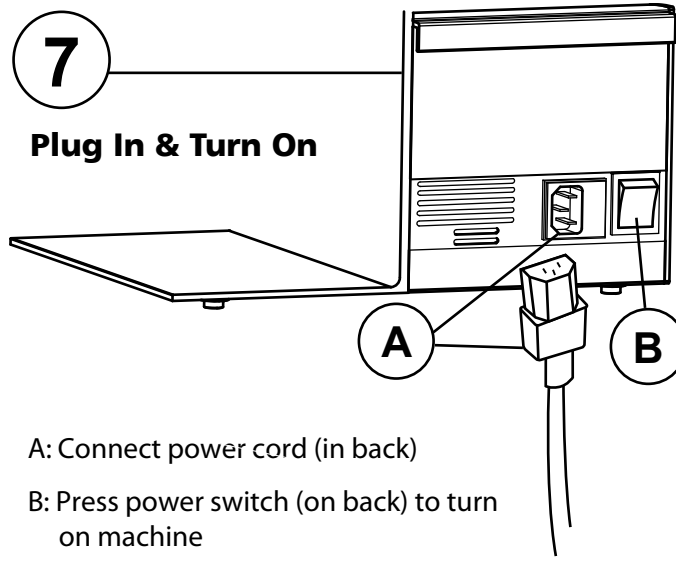

- A: Connect power cord (in back)
- B: Press power switch (on back) to turn on machine

Now you're ready to roll.

QuickSTART Guide



LD6050 Model Shown

- LD6025
- LD6050
- LD6100
- LDX6025
- LDX6050
- LDX6100

Need more help? Download the full manual or contact us. →

LD6025, LD6050, LD6100
LXD6025, LXD6050, LXD6100

Electric Label Dispenser

ITEMS INCLUDED

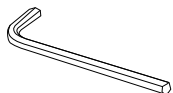
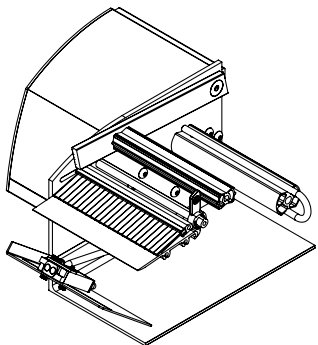

Hex Wrench

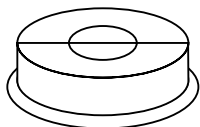

Core Holders (2)

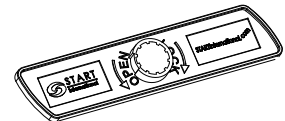

Large Hub Lock

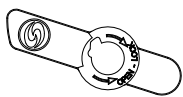

Small Hub Lock

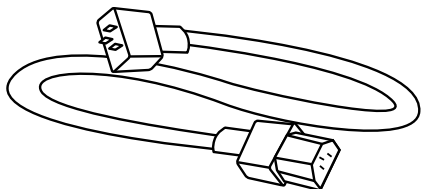

Power Cord

1

Lift Reel Holder Arm

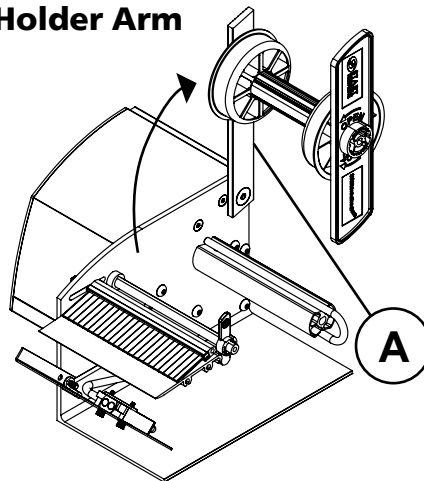

A: Lift reel holder arm slightly past 90° angle and lock into position using provided hex wrench

2

Load Label Roll

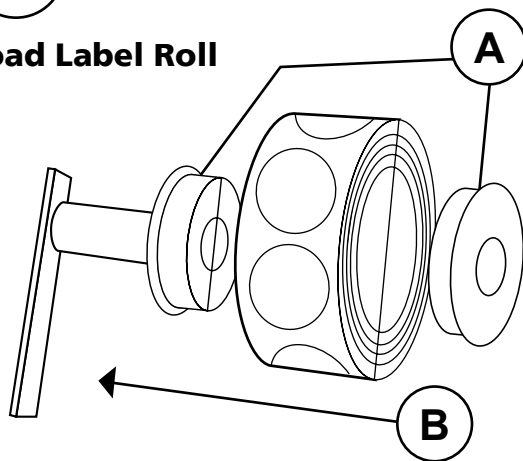

A: Insert core holders (2) into each side of your label roll

B: Slide loaded roll into reel hanger bar

3

Material Guide

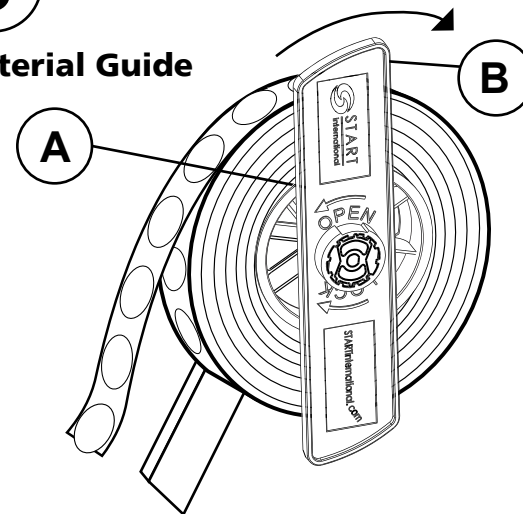

A: Slide large hub lock into reel hanger bar to secure label roll

B: Rotate the large hub lock **lightly** clockwise until it locks into place

4

Remove Lock Rod

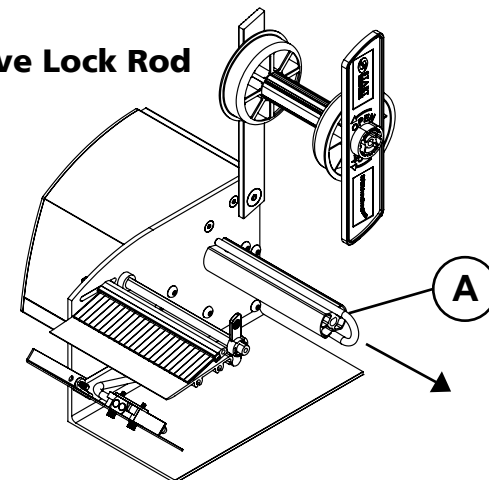

A: Slide lock rod off take-up hub