

instructions

TDH<sub>2</sub>05



**START**<sup>™</sup>  
International



## **TDH2O5 Instructions**

### **Set Up**

1. Remove the tape holding the reel guides and upper tape plate. (For shipping purposes only.)
2. Remove bottle.
3. Remove water tank by tilting it back and pulling forward over the front lip.
4. Remove brushes from water tank and wash with soap and warm water. Rinse brushes to ensure removal of all soap residue.
5. Replace brushes in water tank.  
Brushes must be angled toward the front of the dispenser. Installing backward will lead to tape jams. (Figure 1)
6. Replace water tank.
7. Fill bottle with clean water. Place finger over fill hole and replace bottle into holder.  
Water level can be adjusted by turning the thumbscrew on the water tank.

### **Tape Loading**

1. Adjust reel guides to fit tape width.
2. Place tape roll, adhesive side down, into the back of machine between the reel guides.
3. Manually feed tape:
  - Over the lift roller
  - Over the metal guide bar
  - Under the upper tape plate until the tape is up against the shear blade. (Figure 2)

### **Operation**

1. With power switch OFF, plug power cord into dispenser and then into wall outlet.
2. Check covers to make sure they are securely closed.
3. Turn dispenser ON, power switch will be illuminated.
4. Adjust heater knob to 50% power. The temperature can be adjusted during use for optimal results.
5. Dispense tape by pressing the button corresponding to tape length needed. Pressing X2 will double the tape length. Example: Press "X2" then "30'" to dispense a 60" length. Press RESET to cancel X2 function.

# Maintenance

## Weekly

1. Wipe shear blade with clean cloth. Use IPA for adhesive build-up on blade.
2. Remove water tank, brushes and bottle and wash with warm water and soap.
3. Remove upper tape plate and brush out paper dust.

## Monthly

1. Add several drops of light machine oil to blade oiler. This is done by pulling the oiler away from the blade.
2. Gently push the oiler back into position against the blade.

# Adjustments

## Wetting of brushes

- Adjust the height of the water bottle by turning the screw in the water tank. Higher to apply more water, lower for less water.

## Tape feeding

- The position of the lower feed wheel can be adjusted by using the set screw on the feed assembly. This can be accessed through the large hole in the support bracket. (Figure 3)
- If the tape is slipping and not feeding consistent lengths, turn the screw clockwise to raise the feed wheel. If the tape is being torn or scored by the wheel, turn the screw counter-clockwise to lower the feed wheel.

## Roll Guides

- Raise the roll guides on the metal bar until the guides can slide along the bar. Place the roll guides into the slots that are just wider than the width of the tape. To set roll guides, pull the guide down into the slot on the metal bar and then slide the guide into the bottom slot.

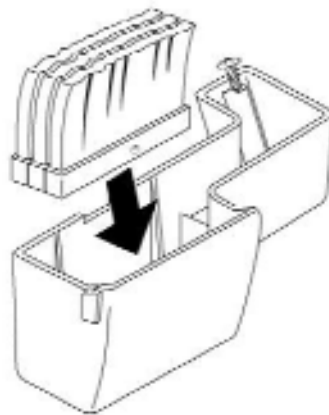

FIGURE 1

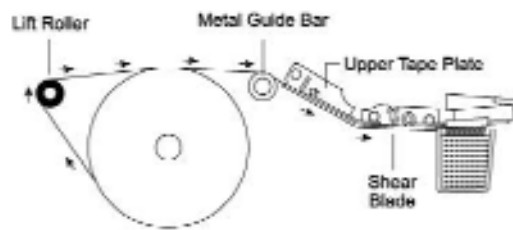

FIGURE 2

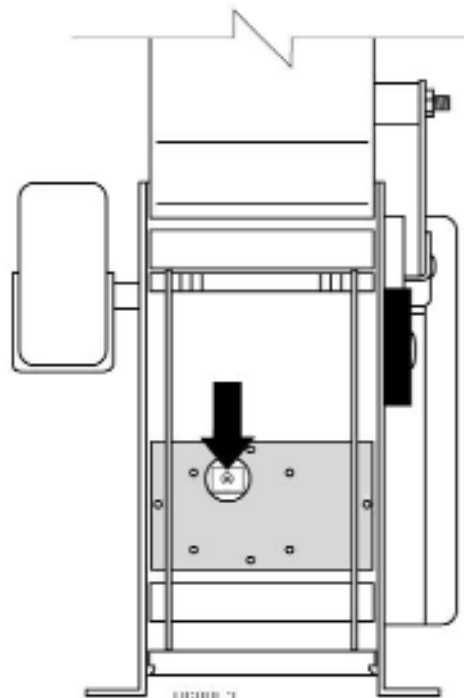
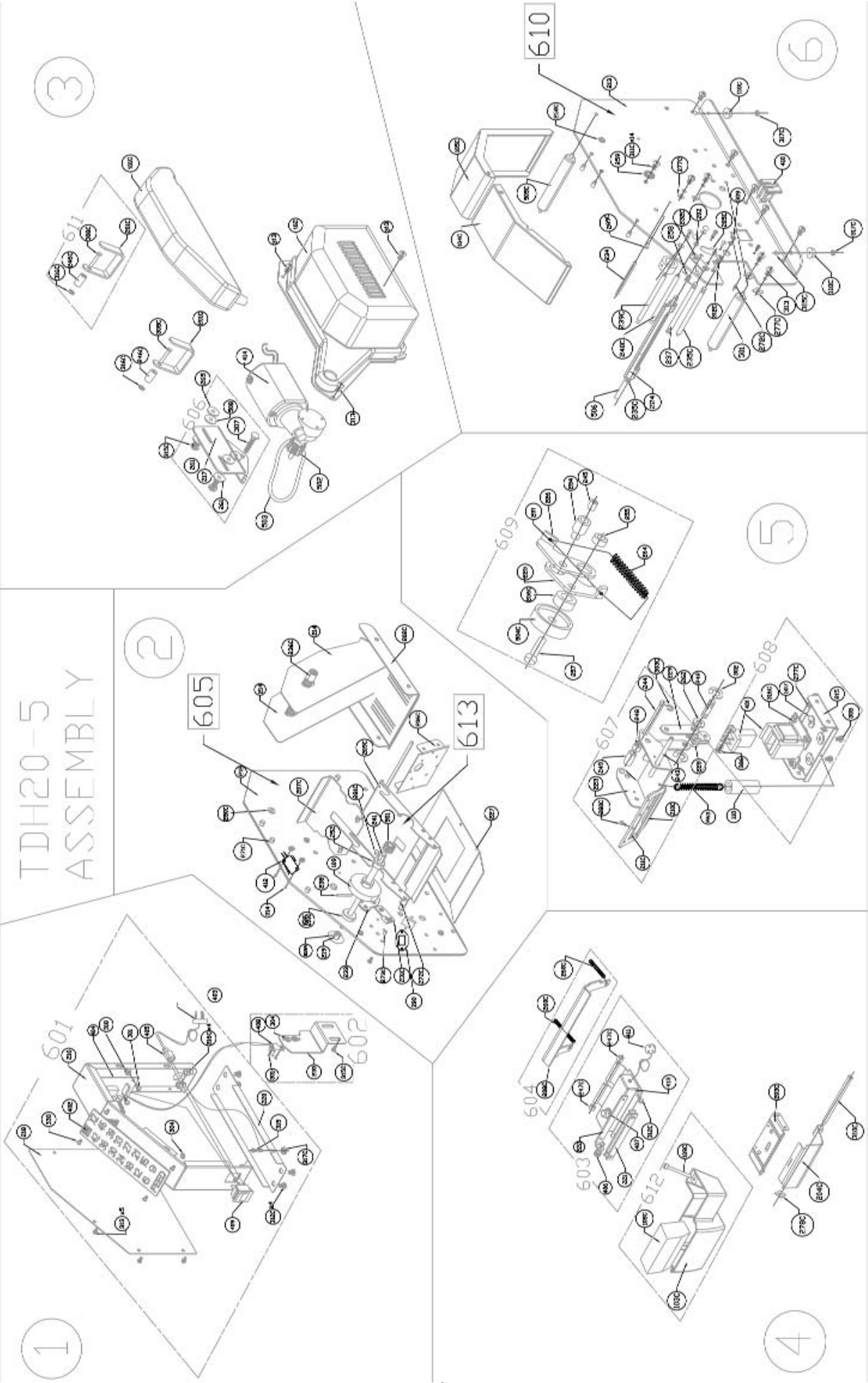
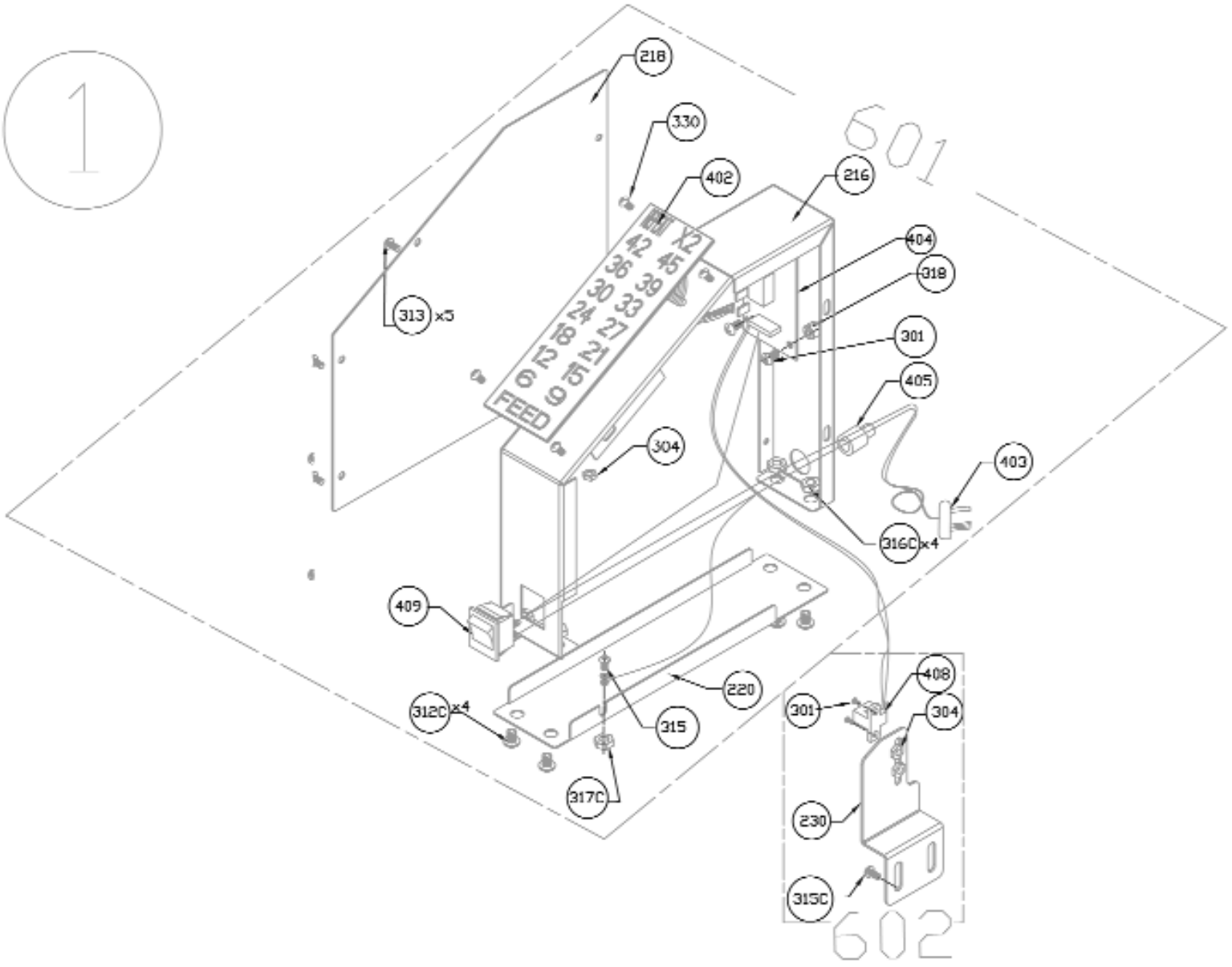

FIGURE 3

# TDH20-5 ASSEMBLY



1



2

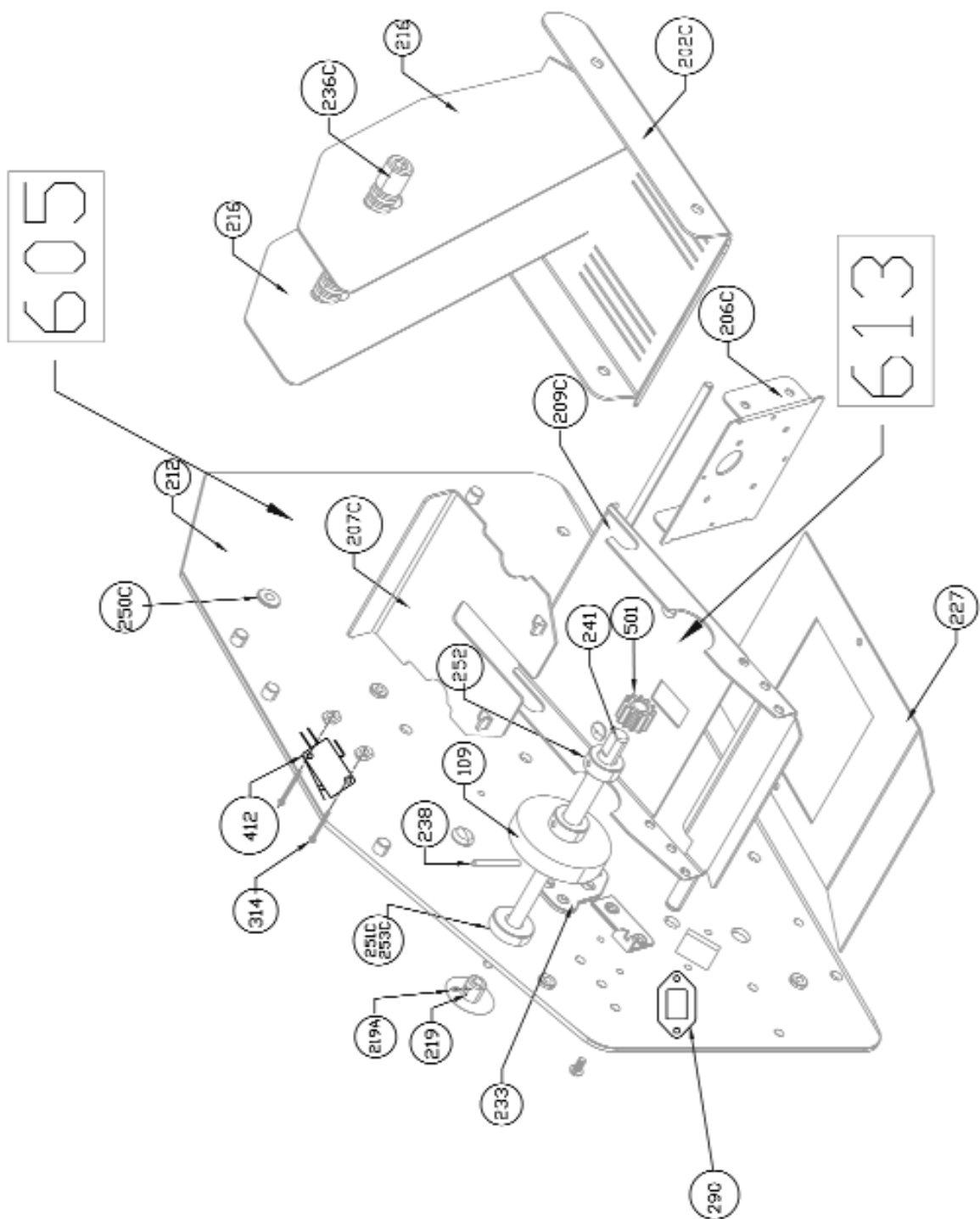

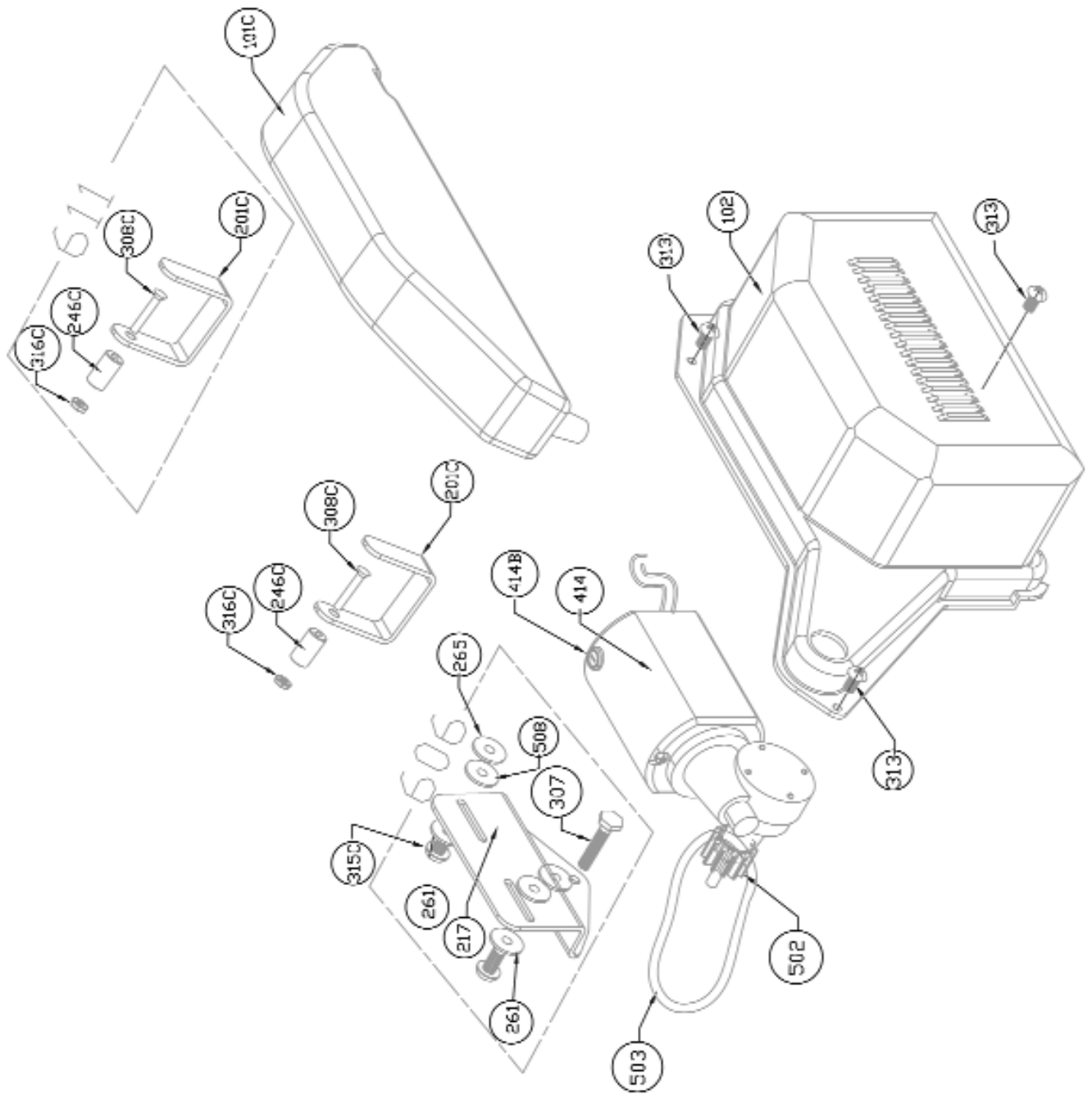



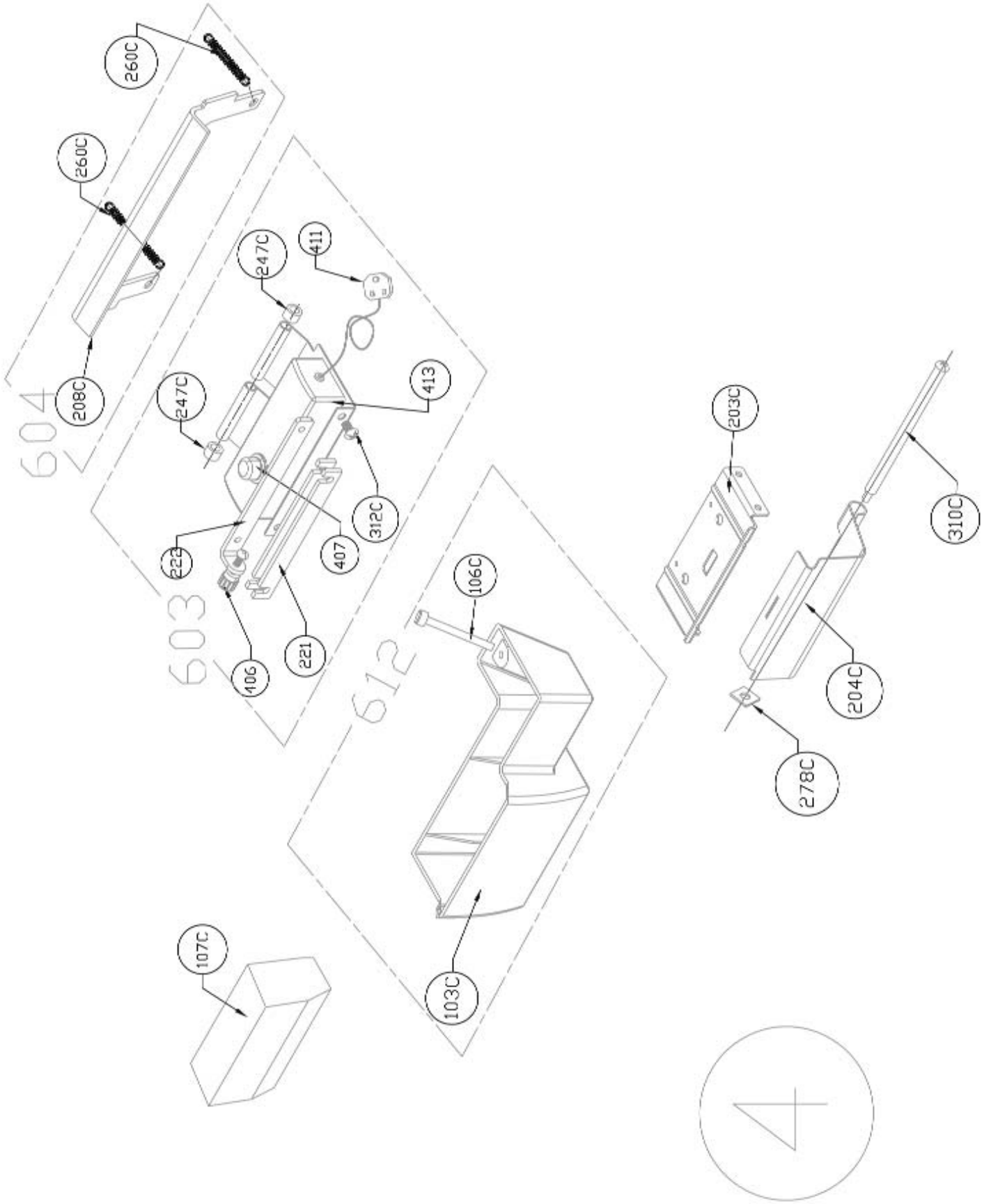

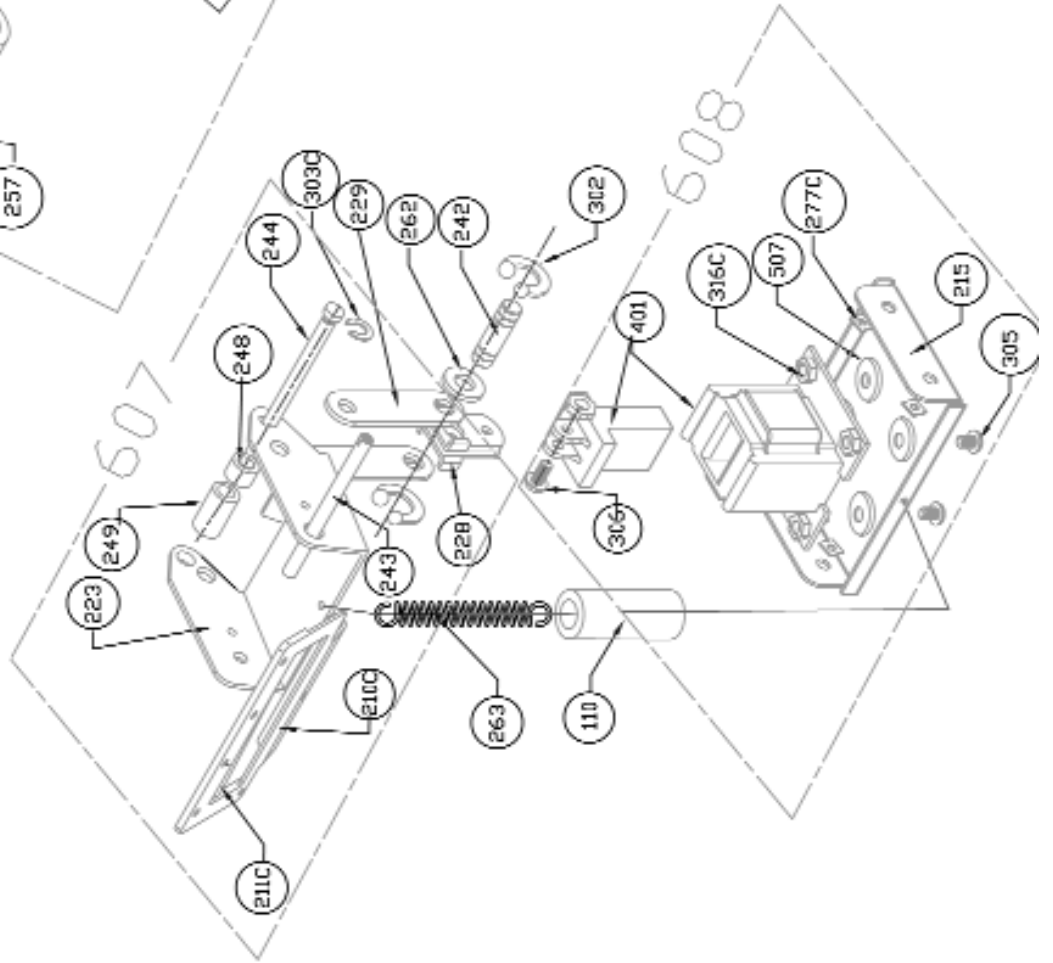
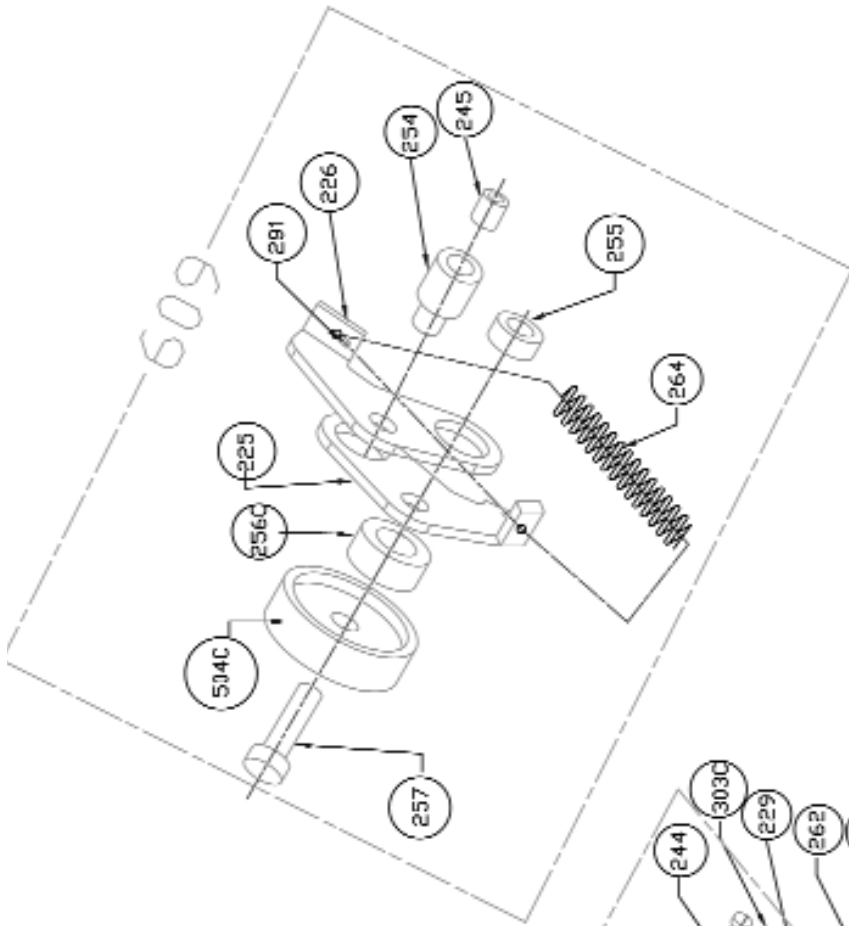

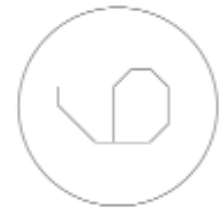
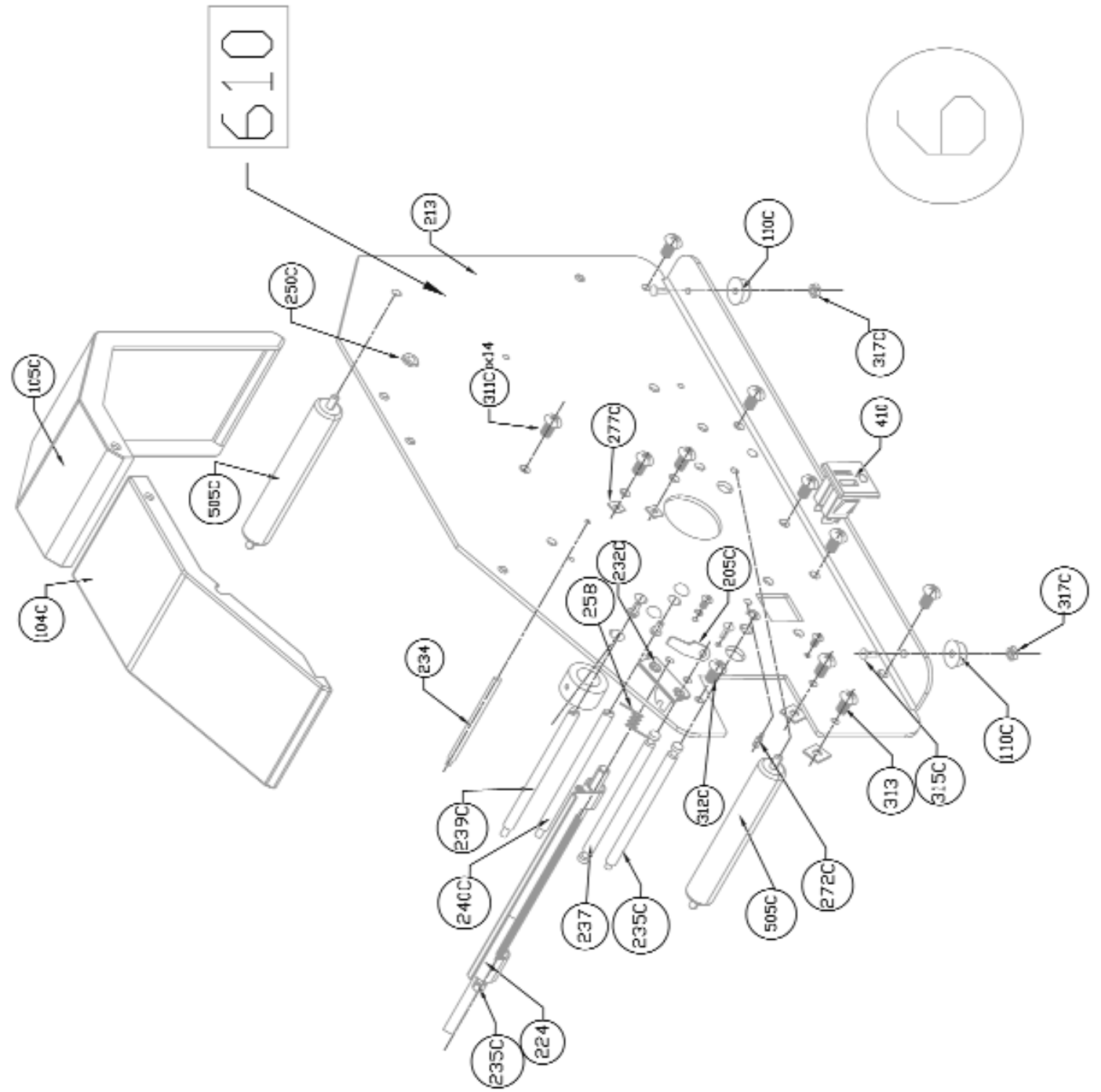



**START™**

**I n t e r n a t i o n a l**

4270 Airborn Drive

Addison, TX 75001, USA

Toll Free 800.259.1986

Tel 972.248.1999

Fax 972.248.1991

[info@startinternational.com](mailto:info@startinternational.com)

[www.startinternational.com](http://www.startinternational.com)