

AUTOMATIC LARGE COLD CUTTER

TBC-552L



 **START**[®]
International

Taping & Labeling Solutions • www.startinternational.com

4270 Airborn Dr.
Addison, TX 75001

972.248.1999 - info@startinternational.com

How to operate TBC-552L

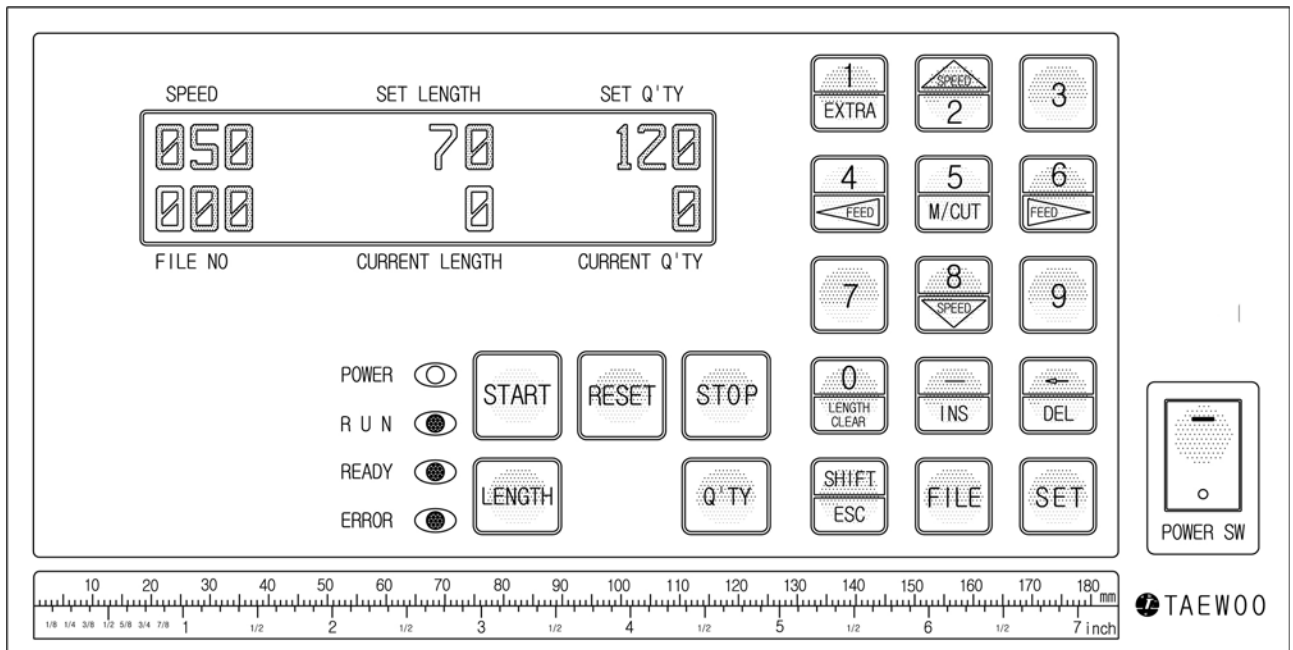

1. An example (Cutting length : 70mm, Cutting quantity : 120 pcs)

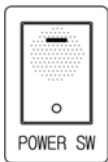

▷ Turn on the POWER SW.

▷ Set cutting length. (Press the following buttons in order.)

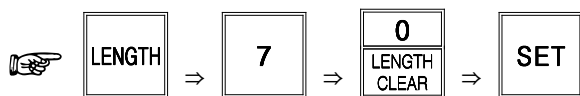

▷ Set cutting quantity.

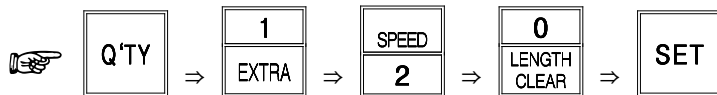

▷ Press START button.



2. Key functions



: Current length on display will be back to "0" at a stop.



: All of current length and current q'ty on display will be back to "0".



: Moving knife only.

- ① to cut the material for test.
- ② to take out the material jammed between knife blades.
- ③ for balancing of knife blades in exchange.



: Cutting additional one.



: Restoring to normal condition in ERROR(red LED) and inputting parameter or program.



: to move the roller manually for mounting the material on the machine or for feeding it forwards or backwards.



– Speed up (The current speed appears on the left-upside of LCD display with "%". Normal speed : 50%, Maximum speed : 100%)

*** Speed up & down is possible in any time(operation or stop) and set-speed will not be changed even though you press RESET button or power off & on.**



– Speed up (The current speed appears on the left-upside of LCD display with "%". Normal speed : 50%, Maximum speed : 0%)

*** Speed up & down is possible in any time(operation or stop) and set-speed will not be changed even though you press RESET button or power off & on.**



: to correct wrong data.



: Function for label cutting (applicable models : TBC-50S, TBC-50SH)

3. Specification

Model No.	Cutting Material	Knife	Power Supply	Max. Cutting Width	Range of Cutting Length	Cutting speed (length : 1M)	Machine Size (Net Weight)	Packing Size (Gross Weight)
TBC-552L	large material	Cold	AC110 /220V, 50/60Hz	210mm	1mm ~ 300M	13 ~ 21 cuts	510×690×940 (85kgs)	830×560×760 (90kgs)

4. Caution for use

- Before use, please confirm the voltage and make the ground(earth) connection.
- **In case of cutting double or triple rolls at the same time, make materials fed oppositely(↶ & ↷), to prevent slipping by roll tension.**
- Do not access hands or any object close to the working knife. (for safety)
- When the knife blade becomes dull, please use it after grinding with the grinding machine. (Please do not let the unskilled person grind manually or install the knife blade.)

HOW TO ADJUST KNIFE

Knife of TBC-520L/530L cuts material as like scissors.

If there is a gab between upper and lower knife, there will be a problem.

So if you have a cutting problem due to gab between upper and lower knife, this documents can help you.

As you can see, the gab can be adjusted by 5 bolts, refer to below image.

Before adjusting gab, please release bolts (#B-15, clamping bolts) a little to make lower knife movable.

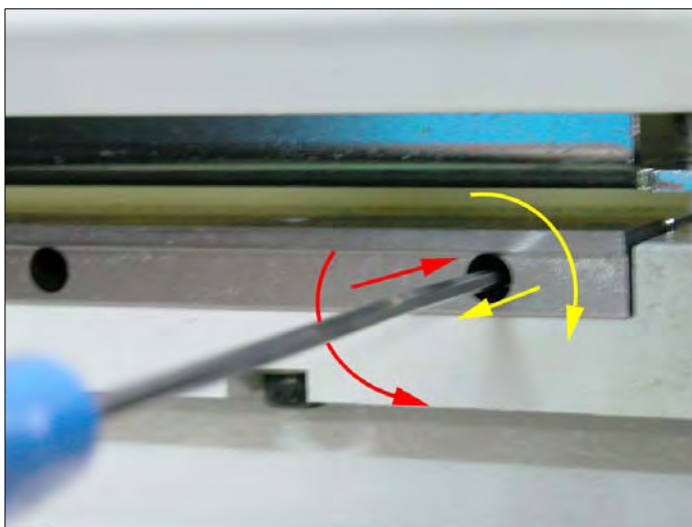
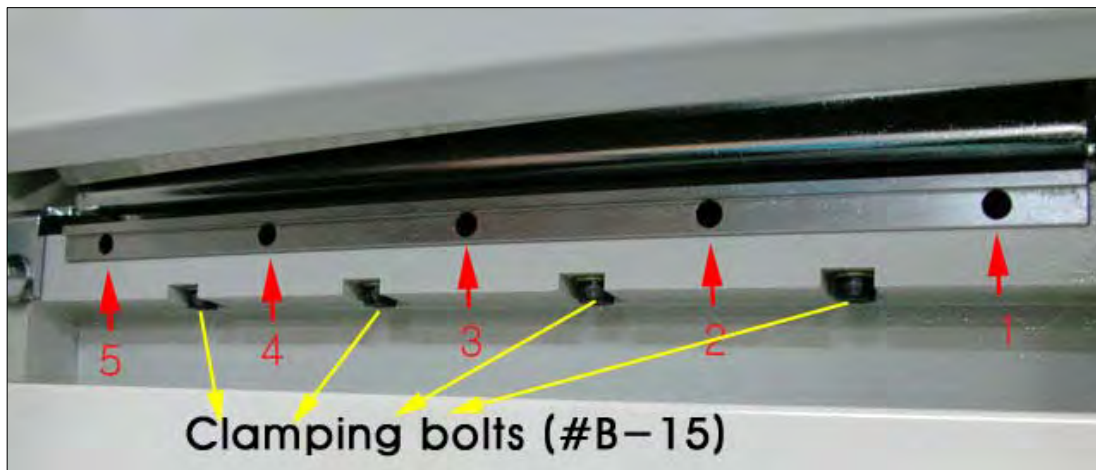

If you turn it by CW (clock wise) the lower knife will be close to upper knife.

And if you turn it by CCW (counter clock wise) the lower knife will move against upper knife.

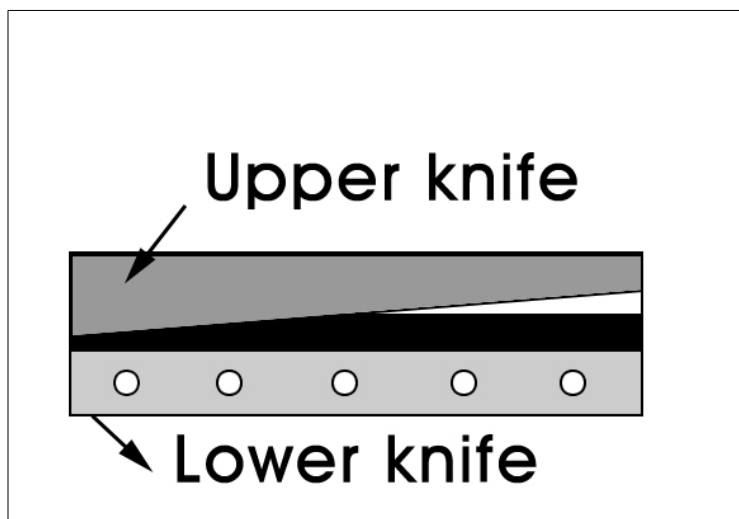

At first, please lay down upper knife a little, please refer to below image.

And then turn no. 5 screw to make lower knife to close to upper knife.

And then make lower knife close to upper knife by turning no. 1~4 screws.

After doing above steps, please test with paper and check which side of

paper is not cut, and make those side of knife close to upper knife by turn proper screws.

Please turn it little by little, we recommend about 5 degrees a time.

After finishing, please fasten all #B-15, clamping bolts.

If you need further information, please contact us at any time.

TBC-552L Part Drawing A (Cutting Part)

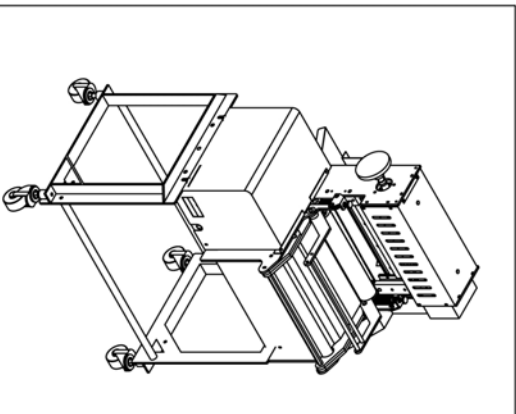
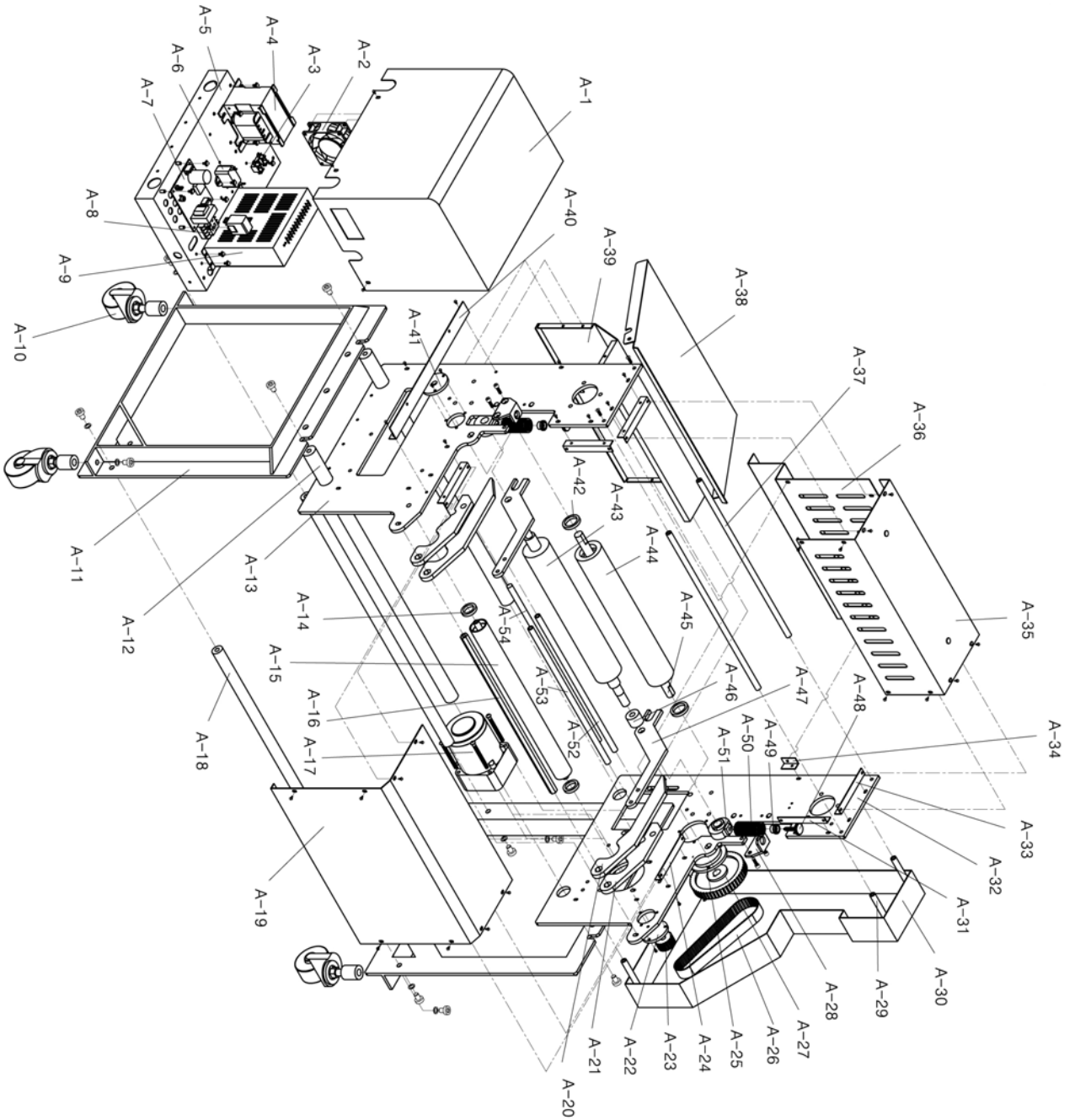

TBC-552L Part List A (Cutting Part)

Part No.	Description	Part No.	Description
A-1	CONTROL CASE	A-28	ROLLER TENSION BRACKET
A-2	FAN	A-29	SAFETY COVER SUPPORT
A-3	TERMINAL	A-30	SAFETY COVER
A-4	TRANSFORMER	A-31	ANGLE NUT
A-5	CONTROL BASE	A-32	LEFT FRAME
A-6	CONDENSER	A-33	ANGLE NUT
A-7	DR BOARD	A-34	ANGLE NUT
A-8	RELAY	A-35	UPSIDE COVER
A-9	DRIVER BOARD	A-36	FRONT COVER
A-10	CASTER	A-37	SUPPORT
A-11	ANGLE FRAME	A-38	MATERIAL GUIDE
A-12	ANGLE SHAFT	A-39	REAR COVER
A-13	RIGHT FRAME	A-40	ANGLE NUT FOR FIXING CONTROL COVER
A-14	BEARING	A-41	ROLLER BEARING HOUSING (RIGHT)
A-15	GUIDE ROLLER	A-42	BEARING
A-16	REAR GUIDE SEXANGLE SHAFT	A-43	LOWER ROLLER
A-17	MOTOR	A-44	UPPER ROLLER
A-18	ANGLE SHAFT	A-45	UPPER ROLLER SHAFT
A-19	FRONT COVER	A-46	FIXING RING
A-20	REAR GUIDE	A-47	LEVER

TBC-552L Part Drawing B (Feeding Part)

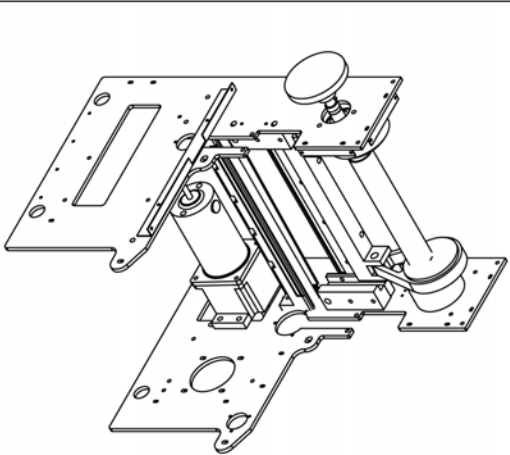
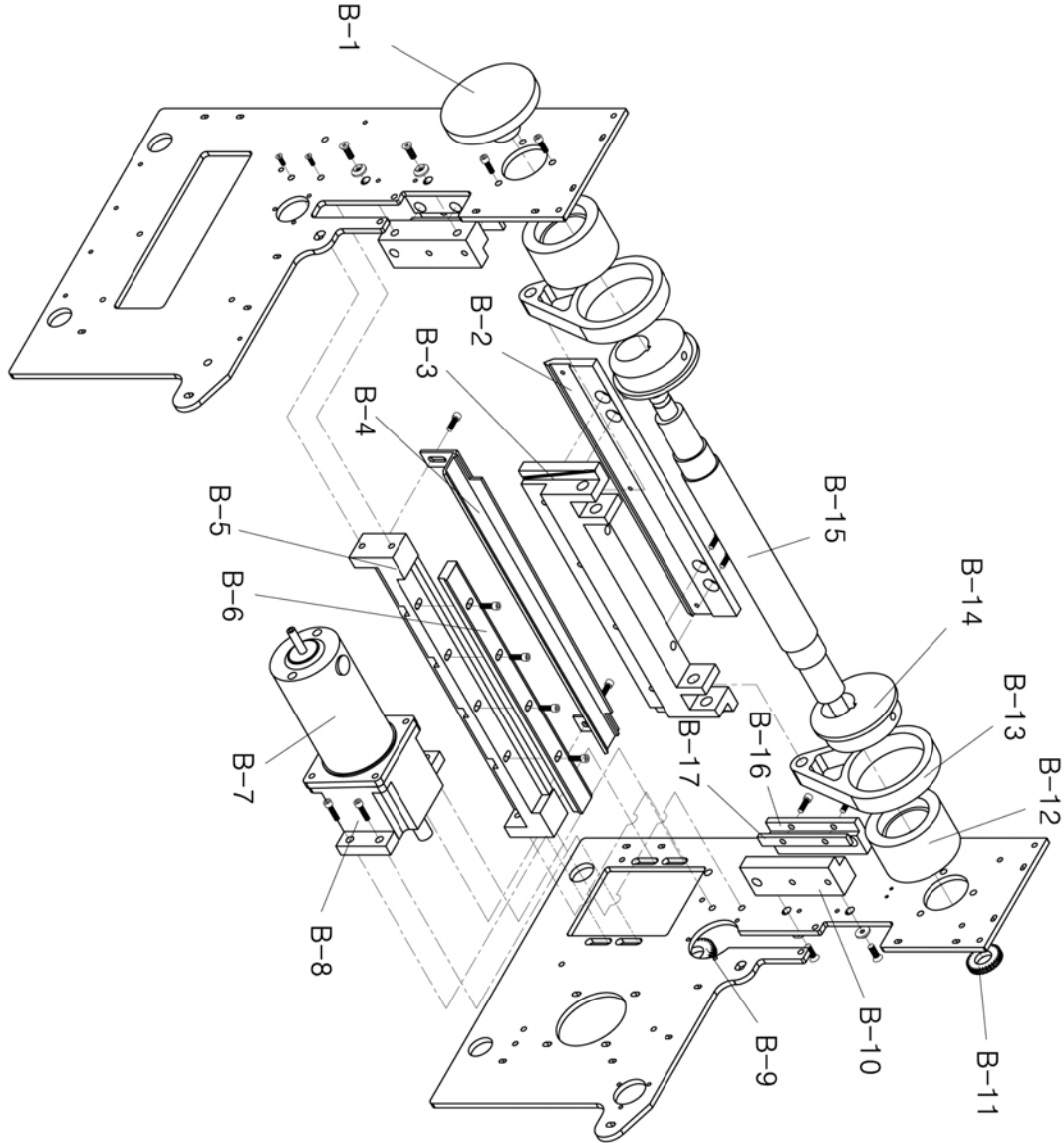

TBC-552L Part List C (Feeding Part)

Part No.	Description	Part No.	Description
B-1	SHAFT KNOB HANDLE		
B-2	LOWER KNIFE		
B-3	LOWER KNIFE FRAME		
B-4	STOPPER		
B-5	LOWER KNIFE BRACKET		
B-6	UPPER KNIFE		
B-7	MOTOR		
B-8	REDUCTION GEAR		
B-9	GEAR		
B-10	PRESSURE PLATE (PAD)		
B-11	GEAR		
B-12	CRANK BEARING HOUSING		
B-13	LINK		
B-14	CRANK		
B-15	CRANK SHAFT		
B-16	PRESSURE PLATE		
B-17	PRESSURE PLATE (PAD)		

TBC-552L Part Drawing C (Feeding Part)

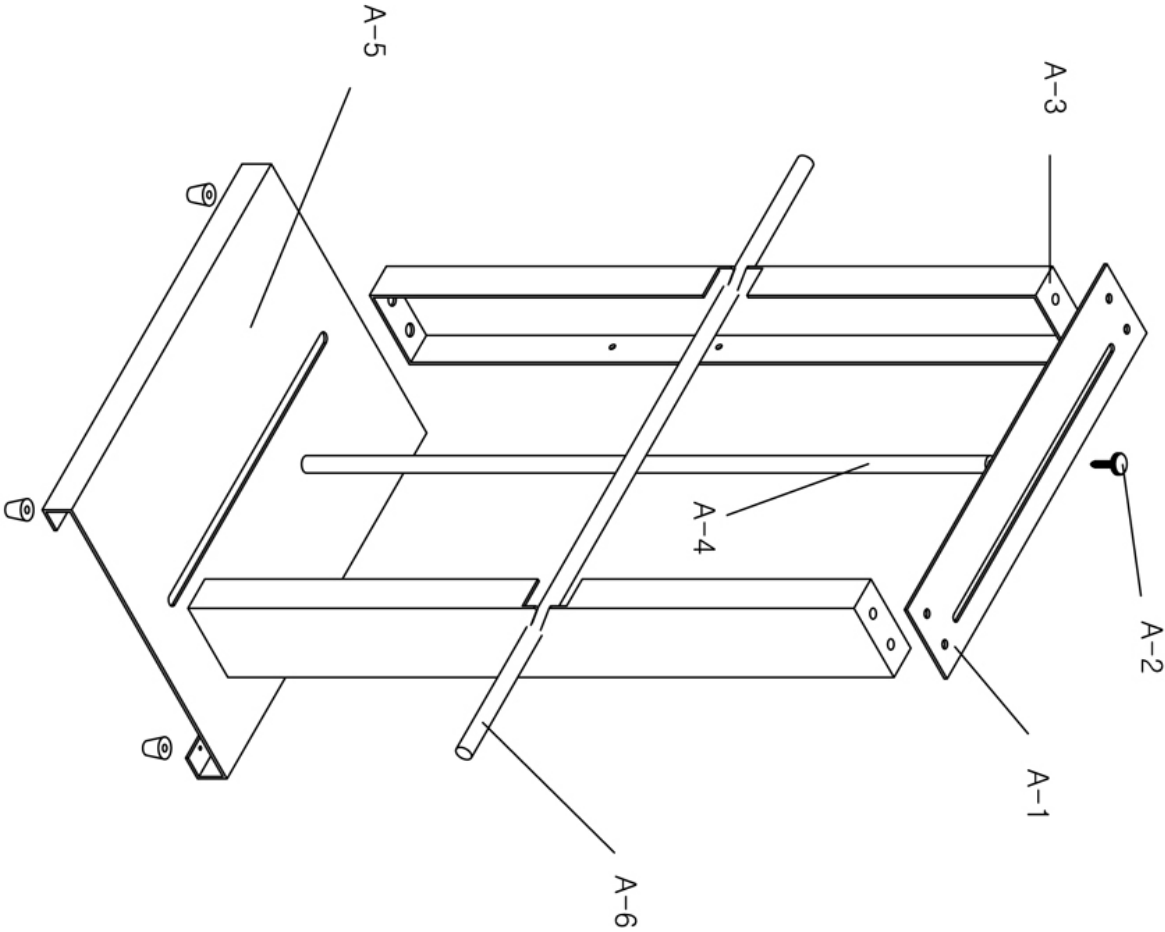

Trouble-shooting of TBC-50 series

No	Troubles		Applicable model	Causes & Measures
1	No power supply		All models	<ul style="list-style-type: none"> - Check if electric cord is connected well. - Check if the fuse blows out or not.
2	Power is on, but no work	Feeding roller doesn't work.	All models	<ul style="list-style-type: none"> - Check if there is inserted any alien substance in roller. - If current length on display is changed, exchange drive board. - If current length on display is not changed, exchange Control board(MB).
		Knife doesn't work.	All models	<ul style="list-style-type: none"> - Check if pressure plates of upper knife are too much fastened or not.
		LCD display doesn't work.	All models	<ul style="list-style-type: none"> - After opening the cover, check the connetion. (especially between Operation & MB board)
		All functions don't work	All models	<ul style="list-style-type: none"> - Check if auto-stop device lies down. If any, raise it up.
3	Material is not cut.		Hot cutter (H, LH, SH, HX)	<ul style="list-style-type: none"> - Check if temperature goes up to set-degree. - Check if knife blades are even(parallel).
4	Material is cut onesidedly.		All models	<ul style="list-style-type: none"> - Check if blades are damaged or weared. - After making both knives close each other by M/CUT button and check if they are even or not. (If they are not even, adjust them by bolts)
5	Cut-length is different from set-length.		All models	<ul style="list-style-type: none"> - Test cutting after loosening material from the reel by hand or attaching feeding device.
6	It cuts before the cutting line of labels.		Label cutter (S, SH)	<ul style="list-style-type: none"> - Move the sensor towards knife side as long as the difference by pushing.
7	It cuts after the cutting line of labels.		Label cutter (S, SH)	<ul style="list-style-type: none"> - Move the sensor towards counter-knife side as long as the difference by pushing.
8	ERROR on LCD & LED	ERROR CODE [064] >Sensor check Er	Label cutter (S, SH)	<ul style="list-style-type: none"> - Trouble in Mark sensor → ? Check if the sensor is connected well or not. ? Check if the sensor is adjusted well or not. (FILE NO 001) ? Check if it is label problem or not.
		ERROR CODE [065] >CUT I/O Error!	All models	<ul style="list-style-type: none"> - Trouble in cutting motor or cutting sensor → ? Upper knife moves 1~3 sec. and ERROR on display. Check the connection of cutting sensor. If not, exchange the cutting sensor. ? Upper knife doesn't move and ERROR on display. Exchange the cutting motor or drive board.
		STOP INPUT !! CHECK STOP INP!	All models	<ul style="list-style-type: none"> - Auto stop device is pressed down or shortage. → raise up the device and check shortage.
		(C)ACORD CTRL-OP AMC-T3KA VER1.7D	All models	<ul style="list-style-type: none"> - Bad connected ROM → Press ROM by hand or connect it again. (If not, change MB board)
		ERROR CODE[065] >CHECK CODE[003]	All models	<ul style="list-style-type: none"> - Change of FILE 003 in program by noise or mis-operation → Initialize the controller. ※ How to Initialize(programs to be initial) : press SET+SHIFT/ESC buttons and RESET button at the same time. (Press RESET later than other two keys.)
9	Operator feels electric current in touch of machine.		All models	<ul style="list-style-type: none"> - Connect the earth cord(green) to any bolt of backside of machine.
10	After exchange ROM, you should do initialize the controller , due to error message, if you cannot do initialization, please press "SHIFT/ESC" button to escape error message screen and then initialize the controller .			

Please contact following address for further information.



4270 Airborn Dr.
Addison, TX 75001
972.248.1999 - info@startinternational.com
www.STARTinternational.com

Please do not disassemble / modify machine or its part without any permission.
If you disassemble / modify machine or its part, you cannot receive warranty/after-sales service.