

4

Load Dispenser

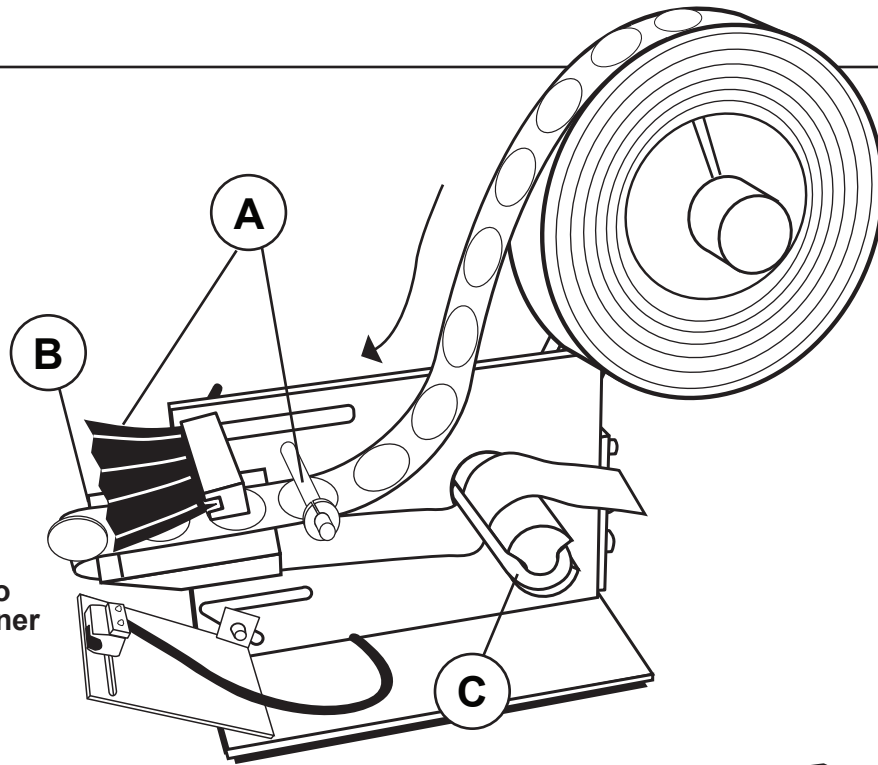

- A:** Feed label liner under guide rod and brush
- B:** Bend liner around strip plate (label will hang slightly over edge for lifting)
- C:** Slide lock rod back onto take-up hub to secure liner

5

Adjust Sensor

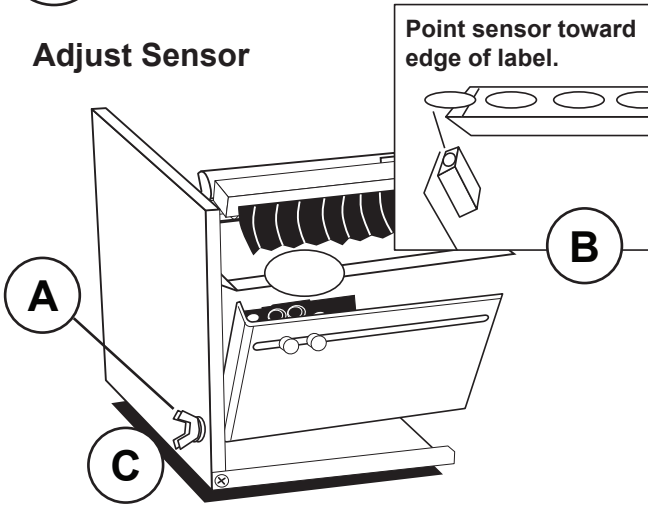

Point sensor toward edge of label.

- A:** Loosen wingscrew to adjust sensor plate
- B:** Point sensor towards edge of label
- C:** Tighten wingscrew to secure in place

6

Plug In and Turn On

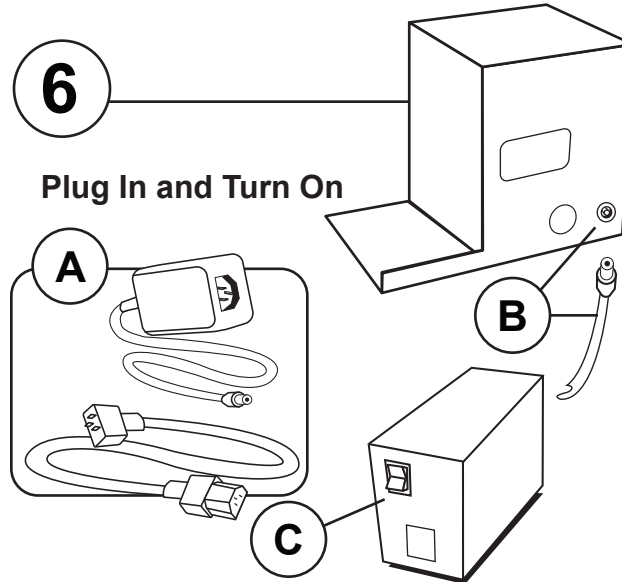

- A:** Assemble power source (2 pieces)
- B:** Connect A/C power (in back) and to wall outlet
- C:** Press power switch (on front) to turn on

Need more help? Download the full manual or contact us

LD2000



Quick Start Guide



4270 Airborn Dr. Addison, TX 75001, USA
972.248.1999 | tech@startinternational.com

startinternational.com

LD2000

Electric Label Dispenser

ITEMS INCLUDED

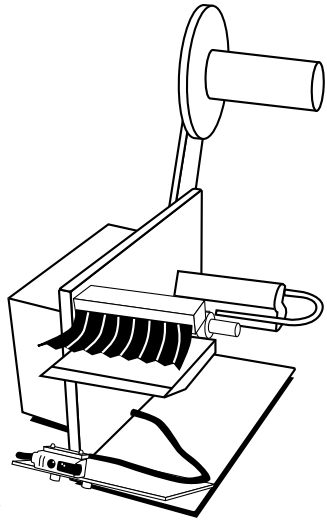

Dispenser

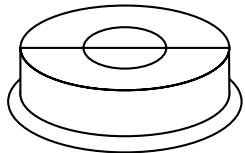

Core Holders (2)

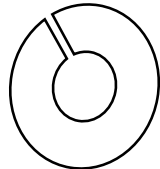

Reel Guide (1)

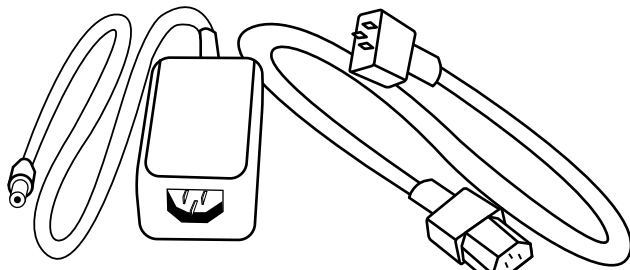

Power Bar and Cord (2 Pieces)

1

Load Label Roll

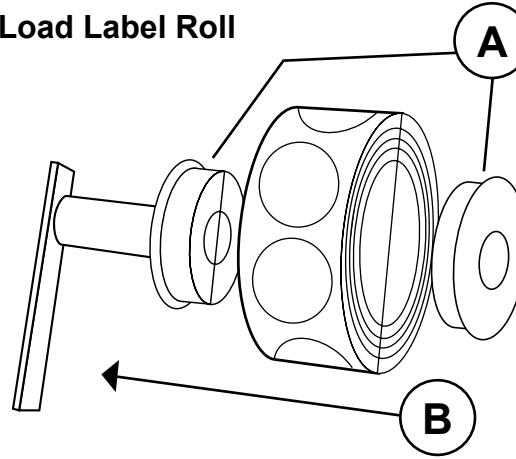

- A:** Insert core holders (2) into each side of your label roll
- B:** Slide loaded roll onto the reel hanger bar

2

Reel Guide

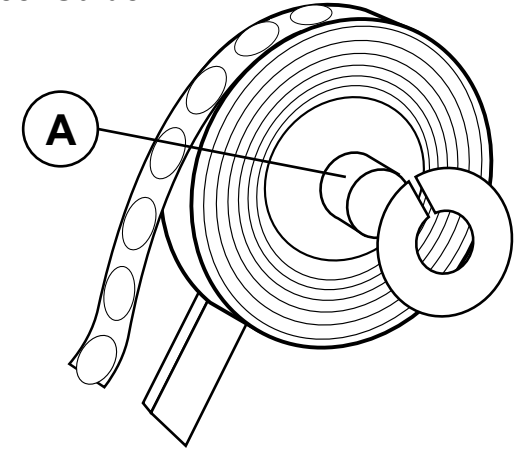

- A:** Slide reel guide onto reel hanger bar to secure your label roll

3

Remove Lock Rod

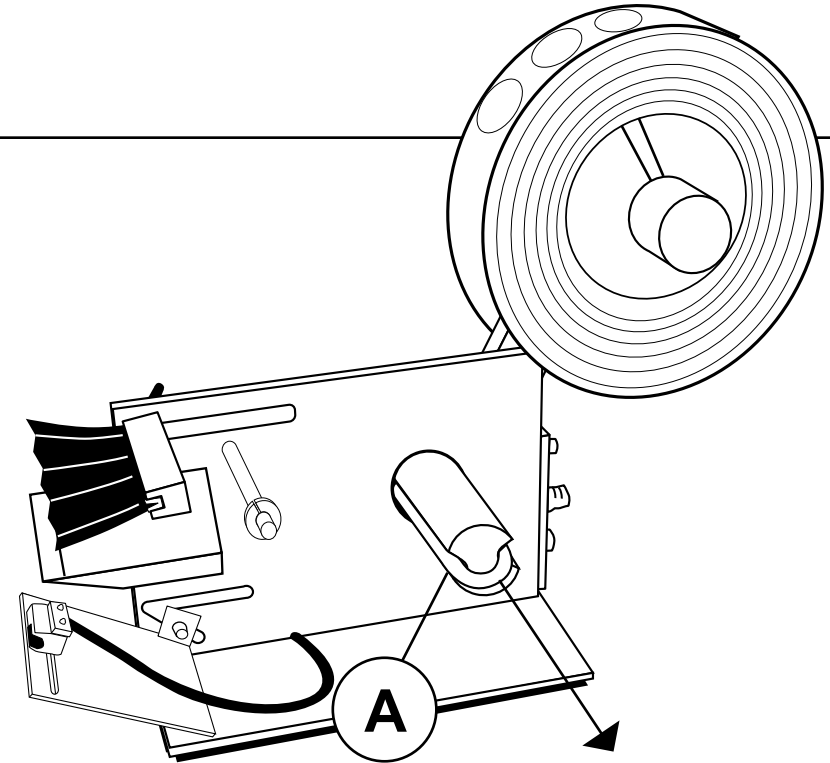

- A:** Slide lock rod off of take-up hub