

5

Load Dispenser

- A:** Feed label liner under guide rod and brush
- B:** Bend liner around strip plate (label will hang slightly over edge for lifting)
- C:** Slide lock rod back onto take-up hub to secure liner

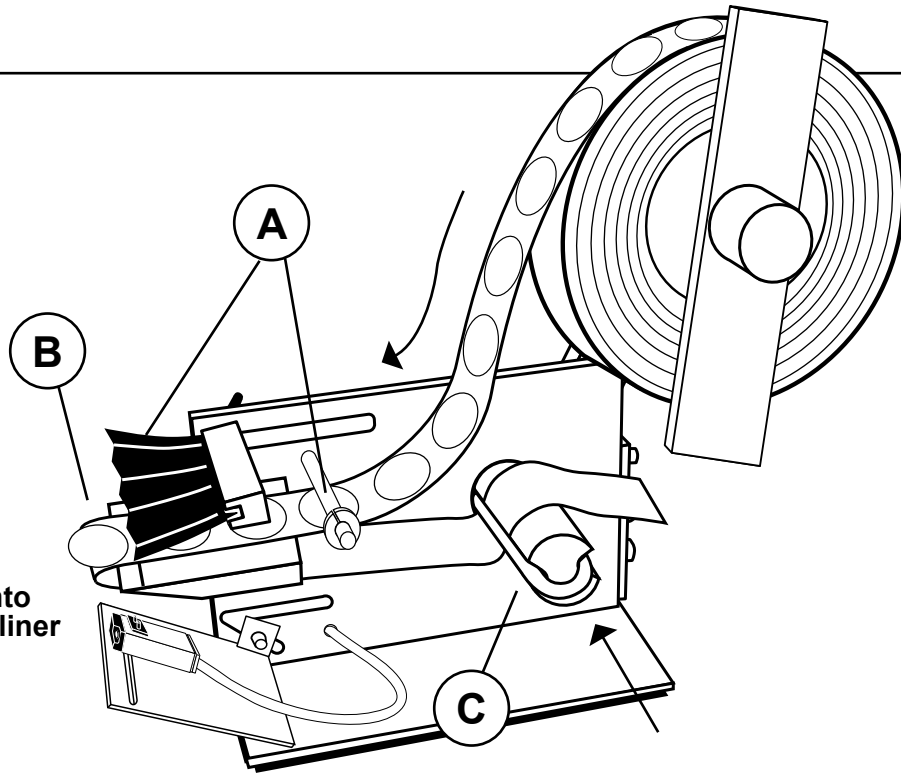

6

Adjust Sensor

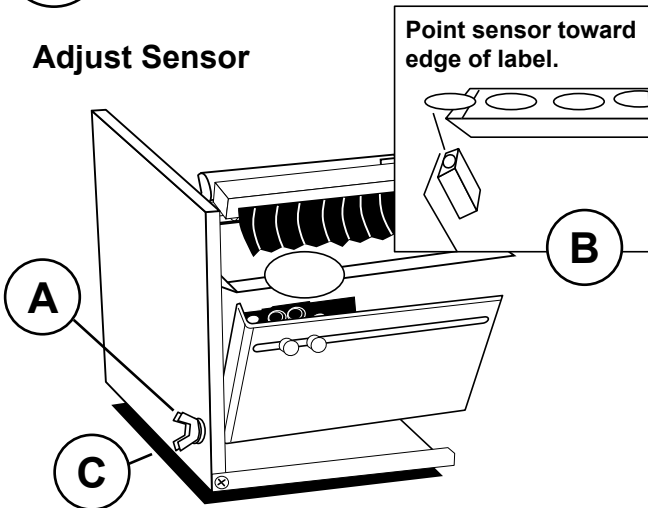

- A:** Loosen wingscrew to adjust sensor plate
- B:** Point sensor towards edge of label
- C:** Tighten wingscrew to secure in place

7

Plug In - Turn On

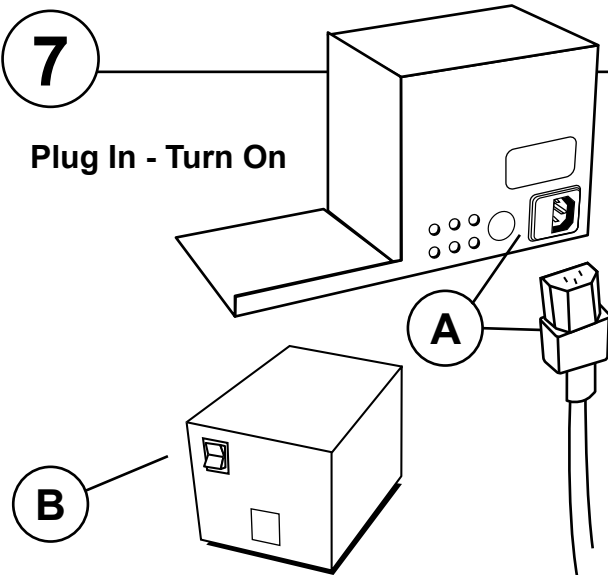

- A:** Connect power cord (in back)
- B:** Press power switch (on front) to turn on the machine

Need more help? Download the full manual or contact us

DC5100



Quick Start Guide



4270 Airborn Dr. Addison, TX 75001, USA  
972.248.1999 | tech@startinternational.com

startinternational.com

**DC5100**

**Electric Label Dispenser**

**ITEMS INCLUDED**

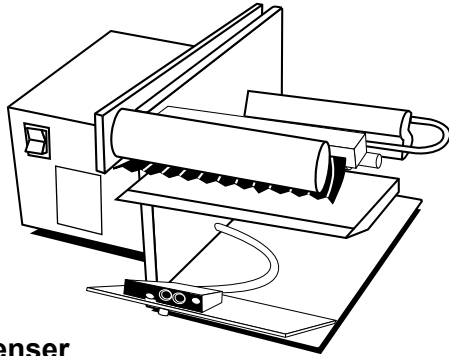

Dispenser

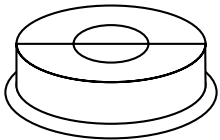

Core Holders (2)

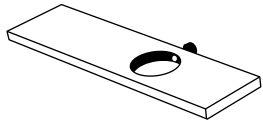

Material Guide

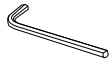

Hex Wrench

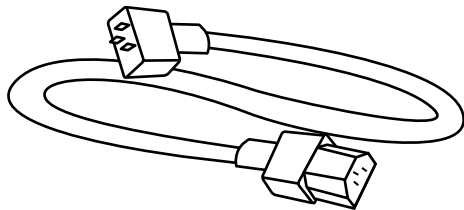

Power Cord

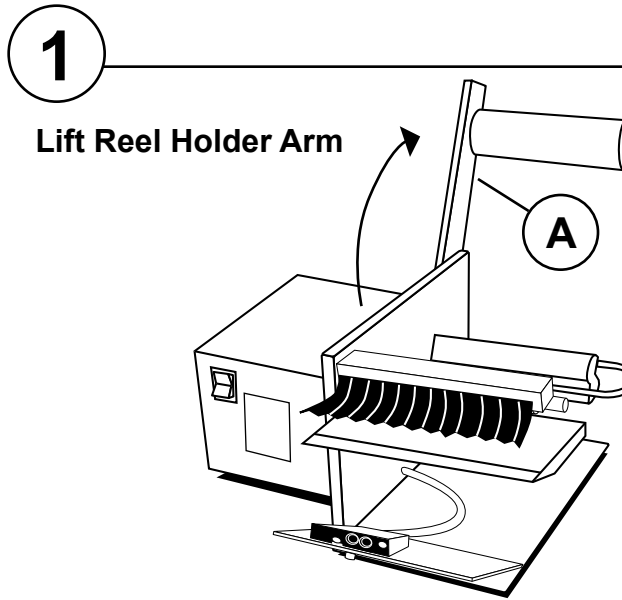

Lift Reel Holder Arm

**A:** Lift reel holder arm slightly past 90° angle and lock into position using provided hex wrench

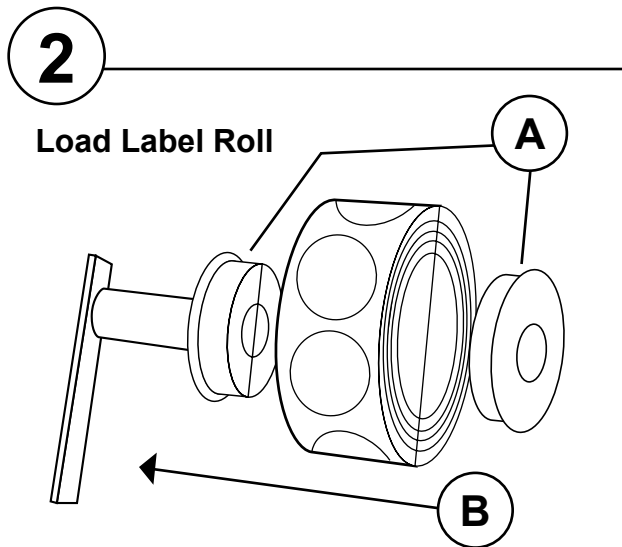

Load Label Roll

**A:** Insert core holders (2) into each side of your label roll  
**B:** Slide loaded roll onto the reel hanger bar

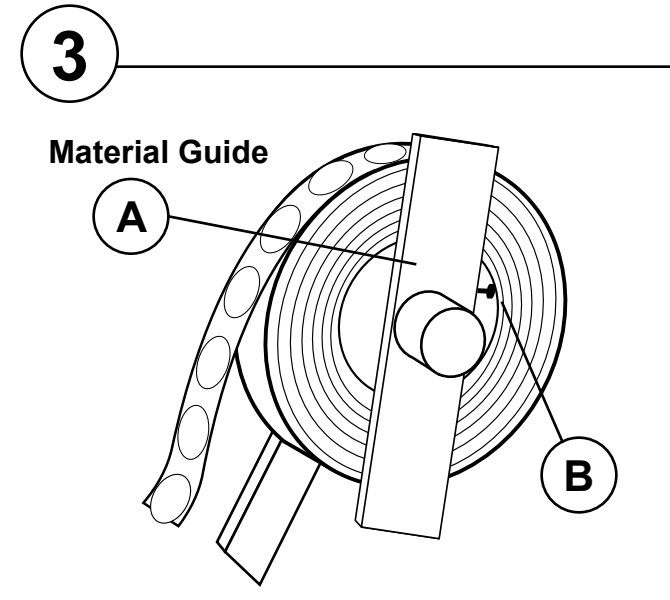

Material Guide

**A:** Slide material guide onto reel hanger bar to secure your label roll

**B:** Tighten lightly using tension screw

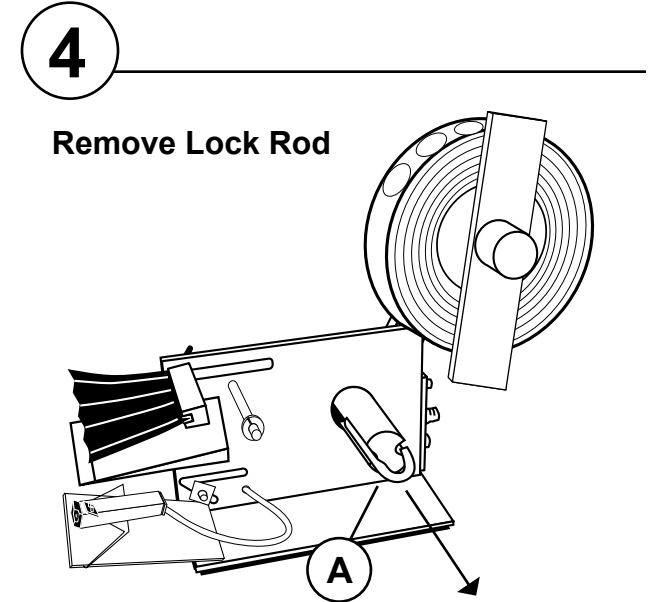

Remove Lock Rod

**A:** Slide lock rod off of take-up hub